

Applications Manual For the Revised NIOSH Lifting Equation

Thomas R. Waters, Ph.D., Vern Putz-Anderson, Ph.D., Arun Garg, Ph.D. Centers for Disease Control & Prevention

Publication date: 01/01/1994

Table of Contents

[DISCLAIMER](#)

[ACKNOWLEDGEMENTS](#)

[Foreword](#)

[Introduction](#)

[1. The Revised Lifting Equation](#)

[1.1 Definition of Terms](#)

[1.1.1 Recommended Weight Limit \(RWL\)](#)

[1.1.2. Lifting Index \(LI\)](#)

[1.1.2. Terminology and Data Definitions](#)

[1.2. Lifting Task Limitations](#)

[1.3. The Equation and Its Function](#)

[1.3.1. Horizontal Component](#)

[1.3.2. Vertical Component](#)

[1.3.3. Distance Component](#)

[1.3.4. Asymmetry Component](#)

[1.3.5. Frequency Component](#)

[1.3.6. Coupling Component](#)

[1.4. The Lifting Index \(LI\)](#)

[1.4.1. Using the RWL and LI to Guide Ergonomic Design](#)

[1.4.2. Rationale and Limitations for LI](#)

[1.4.3. Job-Related Intervention Strategy](#)

[2. Procedures For Analyzing Lifting Jobs](#)

[2.1. Options](#)

[2.1.1. Rationale for Determining Significant Control](#)

[2.1.2. Rationale for Multi-task Analysis Procedure](#)

[2.2. Collect Data \(Step 1\)](#)

[2.3. Single-Task Assessment \(Step 2\)](#)

[2.4. Multi-Task Procedure](#)

[2.4.1. Compute the FIRWL for Each Task](#)

[2.4.2. Compute the STRWL for Each Task](#)

[2.4.3. Compute the FILI for Each Task](#)

[2.4.4. Compute the STLI for Each Task](#)

[2.4.5. Compute the CLI for the Job](#)

[3. Example Problems](#)

[3.1. How to Use the Example Problems](#)

[3.2. Jobs Performed a Few Times Per Shift](#)

[3.2.1. Loading Punch Press Stock, Example 1](#)

[3.2.2. Loading Supply Rolls, Example 2](#)

[3.2.3. Loading Bags Into A Hopper, Example 3](#)
[3.3. Single Task, Performed Repetitively](#)
[3.3.1. Package Inspection, Example 4](#)
[3.3.2. Dish-Washing Machine Unloading, Example 5](#)
[3.3.3. Product Packaging I, Example 6](#)
[3.4. Repetitive Multi-Task, Short-Duration](#)
[3.4.1. Depalletizing Operation, Example 7](#)
[3.4.2. Handling Cans of Liquid, Example 8](#)
[3.5. Repetitive Multi-Task, Long-Duration \(> 2 hrs\)](#)
[3.5.1. Product Packaging II, Example 9](#)
[3.5.2 Warehouse Order Filling, Example 10](#)

[GLOSSARY](#)

[REFERENCES](#)

[POINT OF CONTACT FOR THIS DOCUMENT:](#)

Tables

[Horizontal Multiplier Table \(HM\)](#)
[Vertical Multiplier Table \(VM\)](#)
[Distance Multiplier Table \(DM\)](#)
[Asymmetric Multiplier Table \(AM\)](#)
[Frequency Multiplier Table \(FM\)](#)
[Hand-to-Container Coupling Classification](#)
[Coupling Multiplier Table \(CM\)](#)
[General Design/Redesign Suggestions](#)

Figures

[Graphic Representation of Hand Location](#)
[Graphic Representation of Asymmetry Angle \(A\)](#)
[Single Task Job Analysis Worksheet](#)
[Multi-Task Job Analysis Worksheet](#)
[Loading Punch Press Stock, Example 1](#)
[Job Analysis Worksheet, Example 1](#)
[Modified Job Analysis Worksheet, Example 1](#)
[Loading Supply Rolls, Example 2](#)
[Job Analysis Worksheet, Example 2](#)
[Modified Job Analysis Worksheet, Example 2](#)
[Loading Bags into Hopper, Example 3](#)
[Job Analysis Worksheet, Example 3](#)
[Package Inspection, Example 4](#)
[Job Analysis Worksheet, Example 4](#)
[Dish-Washing Machine Unloading, Example 5](#)
[Job Analysis Worksheet, Example 5](#)
[Modified Job Analysis Worksheet, Example 5](#)
[Packaging I, Example 6](#)
[Job Analysis Worksheet, Example 6](#)
[Modified Job Analysis Worksheet, Example 6](#)
[Depalletizing Operation, Example 7](#)
[Job Analysis Worksheet, Example 7](#)
[Handling Cans of Liquid, Example 8](#)
[Job Analysis Worksheet, Example 8](#)
[Product Packaging II, Example 9](#)
[Job Analysis Worksheet, Example 9](#)
[Warehouse Order Filling, Example 10](#)

[Job Analysis Worksheet, Example 10](#)

[Chart 1](#)

[Chart 2](#)

[Chart 3](#)

DISCLAIMER

Mention of the name of any company or product does not constitute endorsement by the National Institute for Occupational Safety and Health.

DHHS (NIOSH) Publication No. 94-110

ACKNOWLEDGEMENTS

We wish to especially acknowledge the efforts of Arun Garg, Ph.D., Professor of Industrial and Systems Engineering, University of Wisconsin-Milwaukee, who served as the chief technical consultant to NIOSH in the preparation of this document. We also wish to acknowledge the technical assistance of M.M. Ayoub, Ph.D., Don B. Chaffin, Ph.D., Jerome Congleton, Ph.D., Jeffrey Fernandez, Ph.D., Colin Drury, Ph.D., Stephan Konz, Ph.D., Suzanne Rodgers, Ph.D., and Roger Stephens, Ph.D.

The comments and reviews provided by other NIOSH personnel are gratefully acknowledged. They include Steven Sauter, Ph.D. and Dan Habes of the Division of Biomedical and Behavioral Science, and Lawrence J. Fine, M.D., M.P.H. of the Division of Surveillance, Hazard Evaluations, and Field Studies. We also wish to extend our appreciation to Mr. Richard Carlson of the Division of Training and Manpower Development for the illustrations contained in this document. We sincerely appreciate the encouragement and support of Dr. Janet C. Haartz, Director, Division of Biomedical and Behavioral Science.

Foreword

This Manual was developed to provide users of the revised NIOSH lifting equation (1991 version) with methods for accurately applying the lifting equation to a variety of lifting tasks. All necessary terms, definitions, and data requirements for the revised equation are provided in Section 1. Procedures for analyzing single-task and multi-task lifting jobs are described in Section 2. A series of ten lifting tasks is included in Section 3 to illustrate application of the procedure. For each task, a brief job description is provided, followed by a job analysis, and a hazard assessment, including a completed worksheet. Suggestions for redesign of the task are also provided.

The rationale and supporting criteria for the development of the revised NIOSH lifting equation are described in a journal article, Revised NIOSH Equation for the Design and Evaluation of Manual Lifting Tasks, by T. Waters, V. Putz-Anderson, A. Garg, and L. Fine, Ergonomics 1993. {See Appendix I}. The revised equation reflects research findings published subsequent to the publication of the original NIOSH equation (1981) and includes consideration of additional components of lifting tasks such as asymmetrical lifting and quality of hand-container couplings as well as a larger range of work durations and lifting frequencies than did the 1981 equation. It must be noted that application of this equation is limited to those conditions for which it was designed. It does not, for example, address such task factors as one-handed lifting, lifting extremely hot or cold objects, or factors that may increase the risk of a slip or fall and other non-lifting components of job tasks. A complete list of work conditions which are not covered by the 1991 equation is presented in Section 1.2 on page 9 of this Manual. Finally, it should be recognized that all methods require validation. Appropriate studies for the validation of this equation must be conducted to

determine how effective these procedures are in reducing the morbidity associated with manual materials handling.

The equation was designed to assist in the identification of ergonomic solutions for reducing the physical stresses associated with manual lifting. It is our hope that this Manual (1) will assist occupational safety and health practitioners in evaluating lifting tasks and reducing the incidence of low back injuries in workers, and (2) also serve to stimulate further research and debate on the prevention of low back pain, one of the most costly occupational health problems facing our nation.

Janet C. Haartz, Ph.D.
Director, Division of
Biomedical and Behavioral Science

Introduction

Low back pain (LBP) and injuries attributed to manual lifting activities continue as one of the leading occupational health and safety issues facing preventive medicine. Despite efforts at control, including programs directed at both workers and jobs, work-related back injuries still account for a significant proportion of human suffering and economic cost to this nation. The scope of the problem was summarized in a report entitled *Back Injuries*, prepared by the Department of Labor's Bureau of Labor Statistics {DOL(BLS)}, Bulletin 2144, published in 1982.

The DOL's conclusions are consistent with current workers' compensation data indicating that "injuries to the back are one of the more common and costly types of work-related injuries" (National Safety Council, 1990). According to the DOL report, back injuries accounted for nearly 20% of all injuries and illnesses in the workplace, and nearly 25% of the annual workers' compensation payments. A more recent report by the National Safety Council (1990) indicated that overexertion was the most common cause of occupational injury, accounting for 31% of all injuries. The back, moreover, was the body part most frequently injured (22% of 1.7 million injuries) and the most costly to workers' compensation systems.

More than ten years ago, the National Institute for Occupational Safety and Health (NIOSH) recognized the growing problem of work-related back injuries and published the *Work Practices Guide for Manual Lifting* (NIOSH WPG, 1981). The NIOSH WPG (1981) contained a summary of the lifting-related literature before 1981; analytical procedures and a lifting equation for calculating a recommended weight for specified two-handed, symmetrical lifting tasks; and an approach for controlling the hazards of low back injury from manual lifting. The approach to hazard control was coupled to the Action Limit (AL), a resultant term that denoted the recommended weight derived from the lifting equation.

In 1985, the National Institute for Occupational Safety and Health (NIOSH) convened an ad hoc committee of experts who reviewed the current literature on lifting, including the NIOSH WPG (1981). (1) The literature review was summarized in a document entitled *Scientific Support Documentation for the Revised 1991 NIOSH Lifting Equation: Technical Contract Reports*, May 8, 1991, which is available from the National Technical Information Service {NTIS No. PB-91-226-274}. The literature summary contains updated information on the physiological, biomechanical, psychophysical, and epidemiological aspects of manual lifting. Based on the results of the literature review, the ad hoc committee recommended criteria for defining the lifting capacity of healthy workers. The committee used the criteria to formulate the revised lifting equation. The equation was publicly presented in 1991 by NIOSH staff at a national conference in Ann Arbor, Michigan entitled *A National Strategy for Occupational Musculoskeletal Injury Prevention -- Implementation Issues and Research Needs*. (2) Subsequently, NIOSH staff developed the documentation for the equation and played a prominent role in recommending methods for interpreting the results of the

lifting equation.

The revised lifting equation reflects new findings and provides methods for evaluating asymmetrical lifting tasks, and lifts of objects with less than optimal couplings between the object and the worker's hands. The revised lifting equation also provides guidelines for a more diverse range of lifting tasks than the earlier equation (NIOSH WPG, 1981).

The rationale and criterion for the development of the revised NIOSH lifting equation are provided in a separate journal article entitled: Revised NIOSH Equation for the Design and Evaluation of Manual Lifting Tasks, by Waters, Putz-Anderson, Garg, and Fine, 1993. {Appendix I}. We suggest that those practitioners who wish to achieve a better understanding of the data and decisions that were made in formulating the revised equation consult the article by Waters et al., 1993. This article provides an explanation of the selection of the biomechanical, physiological, and psychophysical criterion, as well as a description of the derivation of the individual components of the revised lifting equation. For those individuals, however, who are primarily concerned with the use and application of the revised lifting equation, the present document provides a more complete description of the method and limitations for using the revised equation than does the article by Waters et al. 1993. This document also provides a complete set of examples.

Although the revised lifting equation has not been fully validated, the recommended weight limits derived from the revised equation are consistent with, or lower than, those generally reported in the literature (Waters et al., 1993, [Table 2](#), [Table 4](#), and [Table 5](#)). Moreover, the proper application of the revised equation is more likely to protect healthy workers for a wider variety of lifting tasks than methods that rely only a single task factor or single criterion.

Finally, it should be stressed that the NIOSH lifting equation is only one tool in a comprehensive effort to prevent work-related low back pain and disability. {Other approaches to prevention are described elsewhere (ASPH/NIOSH, 1986)}. Moreover, lifting is only one of the causes of work-related low back pain and disability. Other causes which have been hypothesized or established as risk factors include whole body vibration, static postures, prolonged sitting, and direct trauma to the back. Psychosocial factors, appropriate medical treatment, and job demands (past and present) also may be particularly important in influencing the transition of acute low back pain to chronic disabling pain.

(1) The ad hoc 1991 NIOSH Lifting Committee members included: M.M. Ayoub, Donald B. Chaffin, Colin G. Drury, Arun Garg, and Suzanne Rodgers. NIOSH representatives included Vern Putz-Anderson and Thomas R. Waters.

(2) For this document, the revised 1991 NIOSH lifting equation will be identified simply as "the revised lifting equation." The abbreviation WPG (1981) will continue to be used as the reference to the earlier NIOSH lifting equation, which was documented in a publication entitled Work Practices Guide for Manual Lifting (1981).

1. The Revised Lifting Equation

This section provides the technical information for using the revised lifting equation to evaluate a variety of two-handed manual lifting tasks. Definitions, restrictions/limitations, and data requirements for the revised lifting equation are also provided.

1.1 Definition of Terms

1.1.1 Recommended Weight Limit (RWL)

The RWL is the principal product of the revised NIOSH lifting equation. The RWL is defined for a specific set of task conditions as the weight of the load that nearly all healthy workers could perform over a substantial period of time (e.g., up to 8 hours) without an increased risk of developing lifting-related LBP. By healthy workers, we mean workers who are free of adverse health conditions that would increase their risk of musculoskeletal injury.

The RWL is defined by the following equation:

$$\text{RWL} = \text{LC} \times \text{HM} \times \text{VM} \times \text{DM} \times \text{AM} \times \text{FM} \times \text{CM}$$

A detailed description of the individual components of the equation are provided in Section 1.3 on page 12.

1.1.2. Lifting Index (LI)

The LI is a term that provides a relative estimate of the level of physical stress associated with a particular manual lifting task. The estimate of the level of physical stress is defined by the relationship of the weight of the load lifted and the recommended weight limit.

The LI is defined by the following equation:

$$\text{LI} = \frac{\text{Load Weight}}{\text{Recommended Weight Limit}} = \frac{L}{\text{RWL}}$$

1.1.2. Terminology and Data Definitions

The following list of brief definitions is useful in applying the revised NIOSH lifting equation. For detailed descriptions of these terms, refer to the individual sections where each is discussed.

Methods for measuring these variables and examples are provided in Sections 1 and 2.

Lifting Task	Defined as the act of manually grasping an object of definable size and mass with two hands, and vertically moving the object without mechanical assistance.
Load Weight (L)	Weight of the object to be lifted, in pounds or kilograms, including the container.
Horizontal Location (H)	Distance of the hands away from the mid-point between the ankles, in inches or centimeters (measure at the origin and destination of lift). See Figure 1 .
Vertical Location (V)	Distance of the hands above the floor, in inches or centimeters (measure at the origin and destination of lift). See Figure 1 .
Vertical Travel Distance (D)	Absolute value of the difference between the vertical heights at the destination and origin of the lift, in inches or centimeters.
Asymmetry	Angular measure of how far the object is displaced

Angle (A)	from the front (mid-sagittal plane) of the worker's body at the beginning or ending of the lift, in degrees (measure at the origin and destination of lift). See Figure 2 . The asymmetry angle is defined by the location of the load relative to the worker's mid-sagittal plane, as defined by the neutral body posture, rather than the position of the feet or the extent of body twist.
Neutral Body Position	Describes the position of the body when the hands are directly in front of the body and there is minimal twisting at the legs, torso, or shoulders.
Lifting Frequency (F)	Average number of lifts per minute over a 15 minute period.
Lifting Duration	Three-tiered classification of lifting duration specified by the distribution of work-time and recovery-time (work pattern). Duration is classified as either short (1 hour), moderate (1-2 hours), or long (2-8 hours), depending on the work pattern.
Coupling Classification	Classification of the quality of the hand-to-object coupling (e.g., handle, cut-out, or grip). Coupling quality is classified as good, fair, or poor.
Significant Control	Significant control is defined as a condition requiring precision placement of the load at the destination of the lift. This is usually the case when (1) the worker has to re-grasp the load near the destination of the lift, or (2) the worker has to momentarily hold the object at the destination, or (3) the worker has to carefully position or guide the load at the destination.

1.2. Lifting Task Limitations

The lifting equation is a tool for assessing the physical stress of two-handed manual lifting tasks. As with any tool, its application is limited to those conditions for which it was designed. Specifically, the lifting equation was designed to meet specific lifting-related criteria that encompass biomechanical, work physiology, and psychophysical assumptions and data, identified above. To the extent that a given lifting task accurately reflects these underlying conditions and criteria, this lifting equation may be appropriately applied.

The following list identifies a set of work conditions in which the application of the lifting equation could either under- or over- estimate the extent of physical stress associated with a particular work-related activity. Each of the following task limitations also highlight research topics in need of further research to extend the application of the lifting equation to a greater range of real world lifting tasks.

1. The revised NIOSH lifting equation is based on the assumption that manual handling activities other than lifting are minimal and do not require significant energy expenditure, especially when repetitive lifting tasks are performed. Examples of non-lifting tasks include holding, pushing, pulling, carrying, walking, and climbing. If such non-lifting activities account for more than about

10% of the total worker activity, then measures of workers' energy expenditures and/or heart rate may be required to assess the metabolic demands of the different tasks. The equation will still apply if there is a small amount of holding and carrying, but carrying should be limited to one or two steps and holding should not exceed a few seconds. For more information on assessing metabolic demand, see Garg et al. (1978) or Eastman Kodak (1986).

2. The revised lifting equation does not include task factors to account for unpredicted conditions, such as unexpectedly heavy loads, slips, or falls. Additional biomechanical analyses may be required to assess the physical stress on joints that occur from traumatic incidents. Moreover, if the environment is unfavorable (e.g., temperatures or humidity significantly outside the range of 19 degrees to 26 degrees C {66 degrees to 79 degrees F} or 35% to 50%, respectively), independent metabolic assessments would be needed to gauge the effects of these variables on heart rate and energy consumption.

3. The revised lifting equation was not designed to assess tasks involving one-handed lifting, lifting while seated or kneeling, or lifting in a constrained or restricted work space. (3) The equation also does not apply to lifting unstable loads. For purposes of applying the equation, an unstable load would be defined as an object in which the location of the center of mass varies significantly during the lifting activity, such as some containers of liquid or incompletely filled bags, etc. The equation does not apply to lifting of wheelbarrows, shoveling, or high-speed lifting. (4) For such task conditions, independent and task specific biomechanical, metabolic, and psychophysical assessments may be needed. For information on other assessment methods, refer to Eastman Kodak (1986), Ayoub and Mital (1989), Chaffin and Andersson (1991), or Snook and Ciriello (1991).

4. The revised lifting equation assumes that the worker/floor surface coupling provides at least a 0.4 (preferably 0.5) coefficient of static friction between the shoe sole and the working surface. An adequate worker/floor surface coupling is necessary when lifting to provide a firm footing and to control accidents and injuries resulting from foot slippage. A 0.4 to 0.5 coefficient of static friction is comparable to the friction found between a smooth, dry floor and the sole of a clean, dry leather work shoe (nonslip type). Independent biomechanical modeling may be used to account for variations in the coefficient of friction.

5. The revised lifting equation assumes that lifting and lowering tasks have the same level of risk for low back injuries (i.e. that lifting a box from the floor to a table is as hazardous as lowering the same box from a table to the floor). This assumption may not be true if the worker actually drops the box rather than lowering it all the way to the destination. Independent metabolic, biomechanical, or psychophysical assessments may be needed to assess worker capacity for various lowering conditions. (See references provided above.)

In summary, the Revised NIOSH Lifting Equation does not apply if any of the following occur:

- Lifting/lowering with one hand
- Lifting/lowering for over 8 hours
- Lifting/lowering while seated or kneeling
- Lifting/lowering in a restricted work space
- Lifting/lowering unstable objects
- Lifting/lowering while carrying, pushing or pulling
- Lifting/lowering with wheelbarrows or shovels
- Lifting/lowering with high speed motion (faster than about 30 inches/second)
- Lifting/lowering with unreasonable foot/floor coupling (< 0.4 coefficient of friction between the sole and the floor)
- Lifting/lowering in an unfavorable environment (i.e., temperature significantly outside 66-79 degrees F (19-26 degrees C) range; relative humidity outside 35-50% range)

For those lifting tasks in which the application of the revised lifting equation is not appropriate, a

more comprehensive ergonomic evaluation may be needed to quantify the extent of other physical stressors, such as prolonged or frequent non-neutral back postures or seated postures, cyclic loading (whole body vibration), or unfavorable environmental factors (e.g., extreme heat, cold, humidity, etc.).

Any of the above factors, alone or in combination with manual lifting, may exacerbate or initiate the onset of low back pain.

(3) The research staff of the Bureau of Mines have published numerous studies on lifting while kneeling and in restricted workspaces (See Gallagher et al., 1988; Gallagher and Unger, 1990; and, Gallagher, 1991).

(4) Although lifting speed is difficult to judge, a high speed lift would be equivalent to a speed of about 30 inches/second. For comparison purposes, a lift from the floor to a table-top that is completed in less than about 1 second would be considered high speed.

1.3. The Equation and Its Function

The revised lifting equation for calculating the Recommended Weight Limit (RWL) is based on a multiplicative model that provides a weighting for each of six task variables. The weightings are expressed as coefficients that serve to decrease the load constant, which represents the maximum recommended load weight to be lifted under ideal conditions. The RWL is defined by the following equation:

$$RWL = LC \times HM \times VM \times DM \times AM \times FM \times CM$$

Where:

		METRIC -----	US CUSTOMARY -----
Load Constant	LC	23 kg	51 LB
Horizontal Multiplier	HM	(25/H)	(10/H)
Vertical Multiplier	VM	1-(.003 [V-75])	1-(.0075 [V-30])
Distance Multiplier	DM	.82 + (4.5/D)	.82 + (1.8/D)
Asymmetric Multiplier	AM	1-(.0032A)	1-(.0032A)
Frequency Multiplier	FM	From Table 5	From Table 5
Coupling Multiplier	CM	From Table 7	From Table 7

The term task variables refers to the measurable task descriptors (i.e., H, V, D, A, F, and C);

whereas, the term multipliers refers to the reduction coefficients in the equation (i.e., HM, VM, DM, AM, FM, and CM).

Each multiplier should be computed from the appropriate formula, but in some cases it will be necessary to use linear interpolation to determine the value of a multiplier, especially when the value of a variable is not directly available from a table. For example, when the measured frequency is not a whole number, the appropriate multiplier must be interpolated between the frequency values in the table for the two values that are closest to the actual frequency.

A brief discussion of the task variables, the restrictions, and the associated multiplier for each component of the model is presented in the following sections.

1.3.1. Horizontal Component

1.3.1.1. Definition and Measurement

Horizontal Location (H) is measured from the mid-point of the line joining the inner ankle bones to a point projected on the floor directly below the mid-point of the hand grasps (i.e., load center), as defined by the large middle knuckle of the hand ([Figure 1](#)).

Typically, the worker's feet are not aligned with the mid-sagittal plane, as shown in [Figure 1](#), but may be rotated inward or outward. If this is the case, then the mid-sagittal plane is defined by the worker's neutral body posture as defined above.

If significant control is required at the destination (i.e., precision placement), then H should be measured at both the origin and destination of the lift.

Horizontal Location (H) should be measured. In those situations where the H value can not be measured, then H may be approximated from the following equations:

Metric {All distances in cm}	US Customary {All distances in inches}
$H = 20 + W/2$ for $V \geq 25$ cm	$H = 8 + W/2$ for $V \geq 10$ inches
$H = 25 + W/2$ for $V < 25$ cm	$H = 10 + W/2$ for $V < 10$ inches

Where: W is the width of the container in the sagittal plane and V is the vertical location of the hands from the floor.

1.3.1.2. Horizontal Restrictions

If the horizontal distance is less than 10 inches (25 cm), then H is set to 10 inches (25 cm). Although objects can be carried or held closer than 10 inches from the ankles, most objects that are closer than this cannot be lifted without encountering interference from the abdomen or hyperextending the shoulders. While 25 inches (63 cm) was chosen as the maximum value for H, it is probably too large for shorter workers, particularly when lifting asymmetrically. Furthermore, objects at a distance of more than 25 inches from the ankles normally cannot be lifted vertically without some loss of balance.

1.3.1.3. Horizontal Multiplier

The Horizontal Multiplier (HM) is $10/H$, for H measured in inches, and $25/H$, for H measured in centimeters. If H is less than or equal to 10 inches (25 cm), then the multiplier is 1.0. HM decreases with an increase in H value. The multiplier for H is reduced to 0.4 when H is 25 inches (63 cm). If H is greater than 25 inches, then $HM = 0$. The HM value can be computed directly or determined from [Table 1](#).

1.3.2. Vertical Component

1.3.2.1. Definition and Measurement

Vertical Location (V) is defined as the vertical height of the hands above the floor. V is measured vertically from the floor to the mid-point between the hand grasps, as defined by the large middle knuckle. The coordinate system is illustrated in [Figure 1](#) (page 7).

1.3.2.2. Vertical Restrictions

The vertical location (V) is limited by the floor surface and the upper limit of vertical reach for lifting (i.e., 70 inches or 175 cm). The vertical location should be measured at the origin and the destination of the lift to determine the travel distance (D).

1.3.2.3. Vertical Multiplier

To determine the Vertical Multiplier (VM), the absolute value or deviation of V from an optimum height of 30 inches (75 cm) is calculated. A height of 30 inches above floor level is considered "knuckle height" for a worker of average height (66 inches or 165 cm). The Vertical Multiplier (VM) is $(1 - (.0075 [V - 30]))$ for V measured in inches, and VM is $(1 - (.003 [V - 75]))$, for V measured in centimeters.

When V is at 30 inches (75 cm), the vertical multiplier (VM) is 1.0. The value of VM decreases linearly with an increase or decrease in height from this position. At floor level, VM is 0.78, and at 70 inches (175 cm) height VM is 0.7. If V is greater than 70 inches, then $VM = 0$. The VM value can be computed directly or determined from [Table 2](#).

1.3.3. Distance Component

1.3.3.1. Definition and Measurement

The Vertical Travel Distance variable (D) is defined as the vertical travel distance of the hands between the origin and destination of the lift. For lifting, D can be computed by subtracting the vertical location (V) at the origin of the lift from the corresponding V at the destination of the lift (i.e., D is equal to V at the destination minus V at the origin). For a lowering task, D is equal to V at the origin minus V at the destination.

1.3.3.2. Distance Restrictions

The variable (D) is assumed to be at least 10 inches (25 cm), and no greater than 70 inches {175 cm}. If the vertical travel distance is less than 10 inches (25 cm), then D should be set to the minimum distance of 10 inches (25 cm).

1.3.3.3. Distance Multiplier

The Distance Multiplier (DM) is $(.82 + (1.8/D))$ for D measured in inches, and DM is $(.82 + (4.5/D))$ for D measured in centimeters. For D less than 10 inches (25 cm) D is assumed to be 10 inches (25 cm), and DM is 1.0. The Distance Multiplier, therefore, decreases gradually with an increase in travel distance. The DM is 1.0 when D is set at 10 inches, (25 cm); DM is 0.85 when D

= 70 inches (175 cm). Thus, DM ranges from 1.0 to 0.85 as the D varies from 0 inches (0 cm) to 70 inches (175 cm). The DM value can be computed directly or determined from [Table 3](#).

1.3.4. Asymmetry Component

1.3.4.1. Definition and Measurement

Asymmetry refers to a lift that begins or ends outside the mid-sagittal plane as shown in [Figure 2](#) on page 8. In general, asymmetric lifting should be avoided. If asymmetric lifting cannot be avoided, however, the recommended weight limits are significantly less than those limits used for symmetrical lifting. (5)

An asymmetric lift may be required under the following task or workplace conditions:

1. The origin and destination of the lift are oriented at an angle to each another.
2. The lifting motion is across the body, such as occurs in swinging bags or boxes from one location to another.
3. The lifting is done to maintain body balance in obstructed workplaces, on rough terrain, or on littered floors.
4. Productivity standards require reduced time per lift.

The asymmetric angle (A), which is depicted graphically in [Figure 2](#), is operationally defined as the angle between the asymmetry line and the mid-sagittal line. The asymmetry line is defined as the horizontal line that joins the mid-point between the inner ankle bones and the point projected on the floor directly below the mid-point of the hand grasps, as defined by the large middle knuckle.

The sagittal line is defined as the line passing through the mid-point between the inner ankle bones and lying in the mid-sagittal plane, as defined by the neutral body position (i.e., hands directly in front of the body, with no twisting at the legs, torso, or shoulders). Note: The asymmetry angle is not defined by foot position or the angle of torso twist, but by the location of the load relative to the worker's mid-sagittal plane.

In many cases of asymmetric lifting, the worker will pivot or use a step turn to complete the lift. Since this may vary significantly between workers and between lifts, we have assumed that no pivoting or stepping occurs. Although this assumption may overestimate the reduction in acceptable load weight, it will provide the greatest protection for the worker.

The asymmetry angle (A) must always be measured at the origin of the lift. If significant control is required at the destination, however, then angle A should be measured at both the origin and the destination of the lift.

(5) It may not always be clear if asymmetry is an intrinsic element of the task or just a personal characteristic of the worker's lifting style. Regardless of the reason for the asymmetry, any observed asymmetric lifting should be considered an intrinsic element of the job design and should be considered in the assessment and subsequent redesign. Moreover, the design of the task should not rely on worker compliance, but rather the design should discourage or eliminate the need for asymmetric lifting.

1.3.4.2. Asymmetry Restrictions

The angle A is limited to the range from 0 degrees to 135 degrees. If $A > 135$ degrees, then AM is set equal to zero, which results in a RWL of zero, or no load.

1.3.4.3. Asymmetric Multiplier

The Asymmetric Multiplier (AM) is $1 - (.0032A)$. The AM has a maximum value of 1.0 when the load is lifted directly in front of the body. The AM decreases linearly as the angle of asymmetry (A) increases. The range is from a value of 0.57 at 135 degrees of asymmetry to a value of 1.0 at 0 degrees of asymmetry (i.e., symmetric lift).

If A is greater than 135 degrees, then $AM = 0$, and the load is zero. The AM value can be computed directly or determined from [Table 4](#).

1.3.5. Frequency Component

1.3.5.1. Definition and Measurement

The frequency multiplier is defined by (a) the number of lifts per minute (frequency), (b) the amount of time engaged in the lifting activity (duration), and (c) the vertical height of the lift from the floor. Lifting frequency (F) refers to the average number of lifts made per minute, as measured over a 15-minute period. Because of the potential variation in work patterns, analysts may have difficulty obtaining an accurate or representative 15-minute work sample for computing the lifting frequency (F). If significant variation exists in the frequency of lifting over the course of the day, analysts should employ standard work sampling techniques to obtain a representative work sample for determining the number of lifts per minute. For those jobs where the frequency varies from session to session, each session should be analyzed separately, but the overall work pattern must still be considered. For more information, most standard industrial engineering or ergonomics texts provide guidance for establishing a representative job sampling strategy (e.g., Eastman Kodak Company, 1986).

1.3.5.2 Lifting Duration

Lifting duration is classified into three categories -- short-duration, moderate-duration and long-duration. These categories are based on the pattern of continuous work-time and recovery-time (i.e., light work) periods. A continuous work-time period is defined as a period of uninterrupted work. Recovery-time is defined as the duration of light work activity following a period of continuous lifting. Examples of light work include activities such as sitting at a desk or table, monitoring operations, light assembly work, etc.

1. Short-duration defines lifting tasks that have a work duration of one hour or less, followed by a recovery time equal to 1.2 times the work time {i.e., at least a 1.2 recovery-time to work-time ratio (RT/WT)}.

For example, to be classified as short-duration, a 45-minute lifting job must be followed by at least a 54-minute recovery period prior to initiating a subsequent lifting session. If the required recovery time is not met for a job of one hour or less, and a subsequent lifting session is required, then the total lifting time must be combined to correctly determine the duration category. Moreover, if the recovery period does not meet the time requirement, it is disregarded for purposes of determining the appropriate duration category.

As another example, assume a worker lifts continuously for 30 minutes, then performs a light work task for 10 minutes, and then lifts for an additional 45-minute period. In this case, the recovery time between lifting sessions (10 minutes) is less than 1.2 times the initial 30 minute work time (36 minutes). Thus, the two work times (30 minutes and 45 minutes) must be added together to determine the duration. Since the total work time (75 minutes) exceeds 1 hour, the job is classified as moderate-duration. On the other hand, if the recovery period between lifting sessions was increased to 36 minutes, then the short-duration category would apply, which would result in

a larger FM value.

2. Moderate-duration defines lifting tasks that have a duration of more than one hour, but not more than two hours, followed by a recovery period of at least 0.3 times the work time {i.e., at least a 0.3 recovery-time to work-time ratio (RT/WT)}.

For example, if a worker continuously lifts for 2 hours, then a recovery period of at least 36 minutes would be required before initiating a subsequent lifting session. If the recovery time requirement is not met, and a subsequent lifting session is required, then the total work time must be added together. If the total work time exceeds 2 hours, then the job must be classified as a long-duration lifting task.

3. Long-duration defines lifting tasks that have a duration of between two and eight hours, with standard industrial rest allowances (e.g., morning, lunch, and afternoon rest breaks).

Note: No weight limits are provided for more than eight hours of work.

The difference in the required RT/WT ratio for the short-duration category (less than 1 hour), which is 1.2, and the moderate-duration category (1-2 hours), which is .3, is due to the difference in the magnitudes of the frequency multiplier values associated with each of the duration categories. Since the moderate-duration category results in larger reductions in the RWL than the short-duration category, there is less need for a recovery period between sessions than for the short duration category. In other words, the short duration category would result in higher weight limits than the moderate duration category, so larger recovery periods would be needed.

1.3.5.3. Frequency Restrictions

Lifting frequency (F) for repetitive lifting may range from 0.2 lifts/min to a maximum frequency that is dependent on the vertical location of the object (V) and the duration of lifting [Table 5](#). Lifting above the maximum frequency results in a RWL of 0.0. (Except for the special case of discontinuous lifting discussed above, where the maximum frequency is 15 lifts/minute.)

1.3.5.4. Frequency Multiplier

The FM value depends upon the average number of lifts/min (F), the vertical location (V) of the hands at the origin, and the duration of continuous lifting. For lifting tasks with a frequency less than .2 lifts per minute, set the frequency equal to .2 lifts/minute. For infrequent lifting (i.e., $F < .1$ lift/minute), however, the recovery period will usually be sufficient to use the 1-hour duration category. The FM value is determined from [Table 5](#).

1.3.5.5. Special Frequency Adjustment Procedure

A special procedure has been developed for determining the appropriate lifting frequency (F) for certain repetitive lifting tasks in which workers do not lift continuously during the 15 minute sampling period. This occurs when the work pattern is such that the worker lifts repetitively for a short time and then performs light work for a short time before starting another cycle. As long as the actual lifting frequency does not exceed 15 lifts per minute, the lifting frequency (F) may be determined for tasks such as this as follows:

1. Compute the total number of lifts performed for the 15 minute period (i.e., lift rate times work time).
2. Divide the total number of lifts by 15.
3. Use the resulting value as the frequency (F) to determine the frequency multiplier (FM) from

[Table 5.](#)

For example, if the work pattern for a job consists of a series of cyclic sessions requiring 8 minutes of lifting followed by 7 minutes of light work, and the lifting rate during the work sessions is 10 lifts per minute, then the frequency rate (F) that is used to determine the frequency multiplier for this job is equal to $(10 \times 8)/15$ or 5.33 lifts/minute. If the worker lifted continuously for more than 15 minutes, however, then the actual lifting frequency (10 lifts per minute) would be used.

When using this special procedure, the duration category is based on the magnitude of the recovery periods between work sessions, not within work sessions. In other words, if the work pattern is intermittent and the special procedure applies, then the intermittent recovery periods that occur during the 15-minute sampling period are not considered as recovery periods for purposes of determining the duration category. For example, if the work pattern for a manual lifting job was composed of repetitive cycles consisting of 1 minute of continuous lifting at a rate of 10 lifts/minute, followed by 2 minutes of recovery, the correct procedure would be to adjust the frequency according to the special procedure {i.e., $F = (10 \text{ lifts/minute} \times 5 \text{ minutes})/15 \text{ minutes} = 50/15 = 3.4 \text{ lifts/minute.}$ } The 2-minute recovery periods would not count towards the WT/RT ratio, however, and additional recovery periods would have to be provided as described above.

1.3.6. Coupling Component

1.3.6.1. Definition & Measurement

The nature of the hand-to-object coupling or gripping method can affect not only the maximum force a worker can or must exert on the object, but also the vertical location of the hands during the lift. A good coupling will reduce the maximum grasp forces required and increase the acceptable weight for lifting, while a poor coupling will generally require higher maximum grasp forces and decrease the acceptable weight for lifting.

The effectiveness of the coupling is not static, but may vary with the distance of the object from the ground, so that a good coupling could become a poor coupling during a single lift. The entire range of the lift should be considered when classifying hand-to-object couplings, with classification based on overall effectiveness. The analyst must classify the coupling as good, fair, or poor. The three categories are defined in [Table 6](#). If there is any doubt about classifying a particular coupling design, the more stressful classification should be selected.

1. An optimal handle design has .75 - 1.5 inches (1.9 to 3.8 cm) diameter, greater than or equal to 4.5 inches (11.5 cm) length, 2 inches (5 cm) clearance, cylindrical shape, and a smooth, non-slip surface.
2. An optimal hand-hold cut-out has the following approximate characteristics: greater than or equal to 1.5 inch (3.8 cm) height, 4.5 inch (11.5 cm) length, semi-oval shape, greater than or equal to 2 inch (5 cm) clearance, smooth non-slip surface, and greater than or equal to 0.25 inches (0.60 cm) container thickness (e.g., double thickness cardboard).
3. An optimal container design has less than or equal to 16 inches (40 cm) frontal length, less than or equal to 12 inches (30 cm) height, and a smooth non-slip surface.
4. A worker should be capable of clamping the fingers at nearly 90 degrees under the container, such as required when lifting a cardboard box from the floor.
5. A container is considered less than optimal if it has a frontal length > 16 inches (40 cm), height > 12 inches (30 cm), rough or slippery surfaces, sharp edges, asymmetric center of mass, unstable contents, or requires the use of gloves. A loose object is considered bulky if the load

cannot easily be balanced between the hand-grasps.

6. A worker should be able to comfortably wrap the hand around the object without causing excessive wrist deviations or awkward postures, and the grip should not require excessive force.

1.3.6.2. Coupling Multiplier

Based on the coupling classification and vertical location of the lift, the Coupling Multiplier (CM) is determined from [Table 7](#).

The following decision tree may be helpful in classifying the hand-to-object coupling.

[Figure C1](#)

1.4. The Lifting Index (LI)

As defined earlier, the Lifting Index (LI) provides a relative estimate of the physical stress associated with a manual lifting job.

$$LI = \frac{\text{Load Weight}}{\text{Recommended Weight Limit}} = \frac{L}{RWL}$$

Where Load Weight (L) = weight of the object lifted (lbs or kg).

1.4.1. Using the RWL and LI to Guide Ergonomic Design

The recommended weight limit (RWL) and lifting index (LI) can be used to guide ergonomic design in several ways:

- (1) The individual multipliers can be used to identify specific job-related problems. The relative magnitude of each multiplier indicates the relative contribution of each task factor (e.g., horizontal, vertical, frequency, etc.)
- (2) The RWL can be used to guide the redesign of existing manual lifting jobs or to design new manual lifting jobs. For example, if the task variables are fixed, then the maximum weight of the load could be selected so as not to exceed the RWL; if the weight is fixed, then the task variables could be optimized so as not to exceed the RWL.
- (3) The LI can be used to estimate the relative magnitude of physical stress for a task or job. The greater the LI, the smaller the fraction of workers capable of safely sustaining the level of activity. Thus, two or more job designs could be compared.
- (4) The LI can be used to prioritize ergonomic redesign. For example, a series of suspected hazardous jobs could be rank ordered according to the LI and a control strategy could be developed according to the rank ordering (i.e., jobs with lifting indices above 1.0 or higher would benefit the most from redesign).

1.4.2. Rationale and Limitations for LI

The NIOSH Recommended Weight Limit (RWL) equation and Lifting Index (LI) are based on the concept that the risk of lifting-related low back pain increases as the demands of the lifting task increase. In other words, as the magnitude of the LI increases, (1) the level of the risk for a given worker would be increased, and (2) a greater percentage of the workforce is likely to be at risk for developing lifting-related low back pain. The shape of the risk function, however, is not known. Without additional data showing the relationship between low back pain and the LI, it is impossible

to predict the magnitude of the risk for a given individual or the exact percent of the work population who would be at an elevated risk for low back pain.

To gain a better understanding of the rationale for the development of the RWL and LI, consult the paper entitled Revised NIOSH Equation for the Design and Evaluation of Manual Lifting Tasks by Waters, Putz-Anderson, Garg, and Fine (1993) (Appendix I). This article provides a discussion of the criteria underlying the lifting equation and of the individual multipliers. This article also identifies both the assumptions and uncertainties in the scientific studies that associate manual lifting and low back injuries.

1.4.3. Job-Related Intervention Strategy

The lifting index may be used to identify potentially hazardous lifting jobs or to compare the relative severity of two jobs for the purpose of evaluating and redesigning them. From the NIOSH perspective, it is likely that lifting tasks with a LI > 1.0 pose an increased risk for lifting-related low back pain for some fraction of the workforce (Waters et al., 1993). Hence, the goal should be to design all lifting jobs to achieve a LI of 1.0 or less.

Some experts believe, however, that worker selection criteria may be used to identify workers who can perform potentially stressful lifting tasks (i.e., lifting tasks that would exceed a LI of 1.0) without significantly increasing their risk of work-related injury (Chaffin and Anderson, 1984; Ayoub and Mital, 1989). Those selection criteria, however, must be based on research studies, empirical observations, or theoretical considerations that include job-related strength testing and/or aerobic capacity testing. Nonetheless, these experts agree that nearly all workers will be at an increased risk of a work-related injury when performing highly stressful lifting tasks (i.e., lifting tasks that would exceed a LI of 3.0). Also, informal or natural selection of workers may occur in many jobs that require repetitive lifting tasks. According to some experts, this may result in a unique workforce that may be able to work above a lifting index of 1.0, at least in theory, without substantially increasing their risk of low back injuries above the baseline rate of injury.

2. Procedures For Analyzing Lifting Jobs

This section describes the procedures that should be followed to correctly assess the physical demands of a manual lifting job.

2.1. Options

Prior to the assessment, the analyst must determine (1) if the job should be analyzed as a single-task or multi-task manual lifting job, and (2) if significant control is required at the destination of the lift.

A single-task manual lifting job is defined as a lifting job in which the task variables do not significantly vary from task to task, or only one task is of interest (e.g., worst case analysis). This may be the case if the effects of the other tasks on strength, localized muscle fatigue, or whole-body fatigue do not differ significantly from the worst case task.

On the other hand, multi-task manual lifting jobs, which are defined as jobs in which there are significant differences in task variables between tasks, are more difficult to analyze because each task must be analyzed separately. Therefore, a specialized procedure is used to analyze multi-task manual lifting jobs.

2.1.1. Rationale for Determining Significant Control

When significant control of an object is required at the destination of a lift, the worker must apply

a significant upward force to decelerate the object. Depending upon the velocity of the lift, this deceleration force may be as great as the force required to lift the object at the origin. Therefore, to insure that the appropriate RWL is computed for a lift that requires significant control at the destination, the RWL is calculated at both the origin and the destination of the lift, and the lower of the two values is used to assess the overall lift. The latter procedure is required if (1) the worker has to re-grasp the load near the destination of the lift, (2) the worker has to momentarily hold the object at the destination, or (3) the worker has to position or guide the load at the destination. The purpose of calculating the RWL at both the origin and destination of the lift is to identify the most stressful location of the lift.

2.1.2. Rationale for Multi-task Analysis Procedure

The initial recommendation for analyzing the physical demands of multi-task manual lifting jobs was included in the NIOSH WPG (1981). The procedure was designed to determine the collective effects of all the tasks. The procedure included: (1) determining a frequency-weighted average for each task variable; (2) determining each of the four multipliers, the AL and the MPL, using the frequency-weighted average variables; and, (3) comparing the frequency-weighted average weight with the AL and MPL. The averaging approach, however, can mask the effects of hazardous task variables, resulting in an underestimation of the lifting hazard (Waters, 1991). For example, consider a multi-task job consisting of two separate tasks, each with a frequency of 1 lift/minute and vertical heights (V) of 0 and 60 inches. Although both tasks considered individually would have large penalties for the vertical height factor, when combined in this manner the frequency-weighted (average) V is 30 inches, which cancels the penalty for vertical height, resulting in no reduction in the recommended weight limit. Because of the potential inaccuracies that can occur when task variables are averaged for multi-task assessments, a new multi-task method was developed. The method is described on page 43.

The new method is based on the following assumptions:

1. That performing multiple lifting tasks would increase the physical or metabolic load, and that this increased load should be reflected in a reduced recommended weight limit and increased Lifting Index.
2. That an increase in the Lifting Index depends upon the characteristics of the additional lifting task.
3. That the increase in the Lifting Index due to the addition of one or more tasks is independent of the Lifting Index of any of the preceding tasks (i.e., Lifting Indices from tasks already performed).

Although the procedure does not consider the potential interaction between individual lifting tasks, we believe this effect is minimal.

The new method is based on the concept that the Composite Lifting Index (CLI), which represents the collective demands of the job, is equal to the sum of the largest Single Task Lifting Index (STLI) and the incremental increases in the CLI as each subsequent task is added. The incremental increase in the CLI for a specific task is defined as the difference between the Lifting Index for that task at the cumulative frequency and the Lifting Index for that task at its actual frequency. For example, consider two identical tasks (A and B), each with a lifting frequency of 1 lift/minute.

Using the new concept:

$$CLI = LI_{\text{subscript A},1} + (LI_{\text{subscript B},2} - LI_{\text{subscript B},1})$$

In these equations, the numeric part of the subscript represents the frequency, such that LI subscript B,2 indicates the LI value for Task B at a frequency of 2 lifts/minute and LI subscript B,1

indicates the LI value for Task B at a frequency of 1 lift/minute.

Since task A and B are identical, LI subscript A,1 and LI subscript B,1 cancel out and $CLI = LI$ subscript B,2. As expected, the CLI for the job is equivalent to the LI value for the simple task being performed at a rate of 2 times/minute. Now, if the two tasks are different, then

$$CLI = LI \text{ subscript A,1} + (LI \text{ subscript B,2} - LI \text{ subscript B,1})$$

In this case, LI subscript A,1 and LI subscript B,1 do not cancel each other out. The CLI is equal to the sum of LI subscript A,1, which refers to the demand of Task A, and the increment of demand for Task B, with the increment being equal to the increase in demand when the frequency for Task B is increased from 1 lift/minute (corresponding to the frequency of Task A) to a rate of 2 lifts/minute (corresponding to the sum of the frequencies of Task A and B). Thus, as each additional task is added, the CLI is increased appropriately.

While the new method has not been validated at the workplace, this multi-task version will minimize errors due to averaging; and thereby, provide a more accurate method for estimating the combined effects of multi-tasked lifting jobs than was provided in the NIOSH WPG (1981).

Many of the lifting jobs in the workplace have multiple lifting activities, and therefore could be analyzed as either a single or a multi-task lifting job. When detailed information is needed, however, to specify engineering modifications, then the multi-task approach should be used. On the other hand, the multi-task procedure is more complicated than the single-task procedure, and requires a greater understanding of assessment terminology and mathematical concepts. Therefore, the decision to use the single or multi-task approach should be based on: (1) the need for detailed information about all facets of the multi-task lifting job, (2) the need for accuracy and completeness of data in performing the analysis, and (3) the analyst's level of understanding of the assessment procedures.

To perform a lifting analysis using the revised lifting equation, two steps are undertaken: (1) data is collected at the worksite and (2) the Recommended Weight Limit and Lifting Index values are computed using the single-task or multi-task analysis procedure. These two steps are described in the following sections.

2.2. Collect Data (Step 1)

The relevant task variables must be carefully measured and clearly recorded in a concise format. The Job Analysis Worksheet for either a single-task analysis ([Figure 3](#)) or a multi-task analysis ([Figure 4](#)) provides a simple form for recording the task variables and the data needed to calculate the RWL and the LI values. A thorough job analysis is required to identify and catalog each independent lifting task that comprises the worker's complete job. For multi-task jobs, data must be collected for each individual task. The data needed for each task include the following:

1. Weight of the object lifted. Determine the load weight (L) of the object (if necessary, use a scale). If the weight of the load varies from lift to lift, record the average and maximum weights.
2. Horizontal and vertical locations of the hands with respect to the mid-point between the ankles. Measure the horizontal location (H) and vertical location (V) of the hands at both the origin and destination.
3. Angle of asymmetry. Determine the angle of asymmetry (A) at the origin and destination of the lift.
4. Frequency of lift. Determine the average lifting frequency rate (F), in lifts/min, periodically throughout the work session (average over at least a 15-minute period). If the lifting frequency

varies from session to session by more than two lifts/min, each work session should be analyzed as a separate task. The duration category, however, must be based on the overall work pattern of the entire workshift.

5. Lifting duration. Determine the total time engaged in continuous lifting and the schedule of recovery allowances (i.e., light work assignments) for each lifting task. Compute the recovery-time to work-time ratio to classify the job for work duration (i.e., Short, Moderate, or Long).

6. Coupling type. Classify the hand-to-container coupling based on [Table 6](#).

2.3. Single-Task Assessment (Step 2)

Calculate the RWL at the origin for each lift. For lifting tasks that require significant control at the destination, calculate the RWL at both the origin and the destination of the lift. The latter procedure is required if (1) the worker has to re-grasp the load near the destination of the lift, (2) the worker has to momentarily hold the object at the destination, or (3) the worker has to position or guide the load at the destination. The purpose of calculating the RWL at both the origin and destination of the lift is to identify the most stressful location of the lift. Therefore, the lower of the RWL values at the origin or destination should be used to compute the Lifting Index for the task, since this value would represent the limiting set of conditions.

The assessment is completed on the single-task worksheet by determining the lifting index (LI) for the task of interest. This is accomplished by comparing the actual weight of the load (L) lifted with the RWL value obtained from the lifting equation.

2.4. Multi-Task Procedure

1. Compute the Frequency-Independent Recommended Weight Limit (FIRWL) and Single-Task Recommended Weight Limit (STRWL) for each task.

2. Compute the Frequency-Independent Lifting Index (FILI) and Single-Task Lifting Index (STLI) for each task.

3. Compute the Composite Lifting Index (CLI) for the overall job.

2.4.1. Compute the FIRWL for Each Task

Compute the Frequency Independent Weight Limit (FIRWL) value for each task by using the respective task variables and setting the Frequency Multiplier to a value of 1.0. The FIRWL for each task reflects the compressive force and muscle strength demands for a single repetition of that task. If significant control is required at the destination for any individual task, the FIRWL must be computed at both the origin and the destination of the lift, as described above for a single-task analysis.

2.4.2. Compute the STRWL for Each Task

Compute the Single-Task Recommended Weight Limit (STRWL) for each task by multiplying its FIRWL by its appropriate Frequency Multiplier (FM). The STRWL for a task reflects the overall demands of that task, assuming it was the only task being performed. Note, this value does not reflect the overall demands of the task when the other tasks are considered. Nevertheless, this value is helpful in determining the extent of excessive physical stress for an individual task.

2.4.3. Compute the FILI for Each Task

Compute the Frequency-Independent Lifting Index (FILI) for each task by dividing the maximum

load weight (L) for that task by the respective FIRWL. The maximum weight is used to compute the FILI because the maximum weight determines the maximum biomechanical loads to which the body will be exposed, regardless of the frequency of occurrence. Thus, the FILI can identify individual tasks with potential strength problems for infrequent lifts. If any of the FILI values exceed a value of 1.0, then ergonomic changes may be needed to decrease the strength demands.

2.4.4. Compute the STLI for Each Task

Compute the Single-Task Lifting Index (STLI) for each task by dividing the average load weight (L) for that task by the respective STRWL. The average weight is used to compute the STLI because the average weight provides a better representation of the metabolic demands, which are distributed across the tasks, rather than dependent on individual tasks. The STLI can be used to identify individual tasks with excessive physical demands (i.e., tasks that would result in fatigue). The STLI values do not indicate the relative stress of the individual tasks in the context of the whole job, but the STLI value can be used to prioritize the individual tasks according to the magnitude of their physical stress. Thus, if any of the STLI values exceed a value of 1.0, then ergonomic changes may be needed to decrease the overall physical demands of the task. Note, it may be possible to have a job in which all of the individual tasks have a STLI less than 1.0 and still be physically demanding due to the combined demands of the tasks. In cases where the FILI exceeds the STLI for any task, the maximum weights may represent a significant problem and careful evaluation is necessary.

2.4.5. Compute the CLI for the Job

The assessment is completed on the multi-task worksheet by determining the Composite Lifting Index (CLI) for the overall job. The CLI is computed as follows:

1. The tasks are renumbered in order of decreasing physical stress, beginning with the task with the greatest STLI down to the task with the smallest STLI. The tasks are renumbered in this way so that the more difficult tasks are considered first.
2. The CLI for the job is then computed according to the following formula:

[Figure C2](#)

Note, that (1) the numbers in the subscripts refer to the new task numbers; and, (2) the FM values are determined from [Table 5](#), based on the sum of the frequencies for the tasks listed in the subscripts.

The following example is provided to demonstrate multi-task procedure. Assume that an analysis of a typical three-task job provided the following results:

[Figure C3](#) To compute the Composite Lifting Index (CLI) for this job, the tasks are renumbered in order of decreasing physical stress, beginning with the task with the greatest STLI down to the task with the smallest STLI. In this case, the task numbers do not change. Next, the CLI is computed according to the formula shown on the previous page. The task with the greatest CLI is Task 1 (STLI = 1.6). The sum of the frequencies for Tasks 1 and 2 is 1+2 or 3, and the sum of the frequencies for Tasks 1, 2 and 3 is 1+2+4 or 7. Then, from [Table 5](#), FM subscript 1 is .94, FM subscript 1,2 is .88, and FM subscript 1,2,3 is .70. Finally, the CLI = $1.6 + 1.0(1/.88 - 1/.94) + .67(1/.70 - 1/.88) = 1.6 + .07 + .20 = 1.9$. Note that the FM values were based on the sum of the frequencies for the subscripts, the vertical height, and the duration of lifting.

3. Example Problems

3.1. How to Use the Example Problems

There are several approaches for controlling the stressors related to manual lifting. One approach is to eliminate the manual requirements of the job by using hoists, cranes, manipulators, chutes, conveyors, or lift trucks, or through mechanization or automation. If the manual requirements of the job cannot be eliminated, then the demands of the job should be reduced through ergonomic design/redesign (e.g., modify the physical layout of the job or reduce the frequency or duration of lifting). As a last resort, and if redesign is not feasible, the stress on the worker should be reduced by distributing the stress between two or more workers (e.g., team lifting).

In many cases elimination of manual lifting is not feasible or practical. Thus, ergonomic design/redesign is the best available control strategy. The goal of such a strategy is to reduce the demands of the job by reducing exposure to dangerous loading conditions and stressful body movements.

Ergonomic design/redesign includes: (1) physical changes in the layout of the job, (2) reductions in the lifting frequency rate and/or the duration of the work period, and (3) modifications of the physical properties of the object lifted, such as type, size, or weight and/or improvement of hand-to-object coupling.

The lifting equation and procedures presented in this document were designed to identify ergonomic problems, and evaluate ergonomic design/redesign solutions. By examining the value of each task multiplier, the penalties associated with each job-related risk factor can be evaluated, thereby determining their relative importance in consideration of alternate workplace designs. The task factors that cause the greatest reduction in the load constant should be considered as the first priority for job redesign.

Ten examples are provided to demonstrate the proper application of the lifting equation and procedures. The procedures provide a method for determining the level of physical stress associated with a specific set of lifting conditions, and assist in identifying the contribution of each job-related factor. The examples also provide guidance in developing an ergonomic redesign strategy. Specifically, for each example, a job description, job analysis, hazard assessment, redesign suggestion, illustration, and completed worksheet are provided. The ten examples were chosen to provide a representative sample of lifting jobs for which the application of this equation was suitable.

Note, you might obtain slightly different values from those displayed in the worksheet examples due to differences in rounding, especially when these values are compared to those determined from computerized versions of the equation. These differences should not be significant. Also, for these examples, multipliers are rounded to two places to the right of the decimal and weight limit (RWL, FIRWL, and STRWL) and lifting index values (LI, FILI, STLI, and CLI) are rounded to one place to the right of the decimal.

The examples are organized as follows:

A. Single Task, Performed a Few Times Per Shift

- Loading Punch Press Stock, Example 1
- Loading Supply Rolls, Example 2
- Loading Bags Into A Hopper, Example 3

B. Single Task, Performed Repetitively

- Package Inspection, Example 4
- Dish-Washing Machine Unloading, Example 5
- Product Packaging I, Example 6

C. Multi-Task, Short Duration (1 hr or less)

Depalletizing Operation, Example 7
Handling Cans of Liquid, Example 8

D. Multi-Task, Long Duration (more than 2 hours but less than 8)
Product Packaging II, Example 9
Warehouse Order Filling, Example 10

To help clarify the discussion of the 10 example problems, and to provide a useful reference for determining the multiplier values, each of the six multipliers used in the equation have been reprinted in tabular form in [Table 1](#), [Table 2](#), [Table 3](#), [Table 4](#), [Table 5](#) and [Table 7](#) on the following page.

A series of general design/redesign suggestions for each job-related risk factor are provided in [Table 8](#). These suggestions can be used to develop a practical ergonomic design/redesign strategy.

3.2. Jobs Performed a Few Times Per Shift

3.2.1. Loading Punch Press Stock, Example 1

3.2.1.1. Job Description

[Figure 5](#) illustrates a common oversight in physically stressful jobs. A punch press operator routinely handles small parts, feeding them into a press and removing them. A cursory view of this task may overlook the fact that once per shift the operator must load a heavy reel of supply stock (illustrated at floor height) from the floor onto the machine. The diameter of the reel is 30 inches, the width of the reel between the worker's hands is 12 inches, and the reel weighs 44 lb. Significant control of the load is required at the destination of the lift due to the design of the machine. Also, the worker cannot get closer to the roll (i.e., between the legs) because the roll is too awkward.

3.2.1.2. Job Analysis

The task variable data are measured and recorded on the job analysis worksheet ([Figure 6](#)). Assuming the operator lifts the reel in the plane shown, rather than on the side of the machine, the vertical height (V) at the origin is 15 inches, the vertical height (V) at the destination is 63 inches, and the horizontal distance (H) is 23 inches at both the origin and the destination of the lift. The activity occurs only once per shift, so F is assumed to be < 0.2 (see [Table 5](#)), and duration is assumed to be less than 1 hour.

No asymmetric lifting is involved (i.e., A = 0), and according to [Table 6](#), the couplings are classified as fair because the object is irregular and the fingers can be flexed about 90 degrees. Since significant control is required at the destination, the RWL must be computed at both the origin and the destination of the lift.

The multipliers are determined from the lifting equation or from ([Table 1](#), [Table 2](#), [Table 3](#), [Table 4](#), [Table 5](#), and [Table 7](#)). The CM is .95 at the origin and 1.0 at the destination, due to the difference in the vertical height at the origin and destination. As shown in [Figure 6](#), the RWL for this activity is 16.3 lb. at the origin and 14.5 lb. at the destination.

3.2.1.3. Hazard Assessment

The weight to be lifted (44 lb.) is greater than the RWL at both the origin and the destination of the lift (16.3 lb. and 14.5 lb., respectively). The LI at the origin is 44/16.3 or 2.7, and the LI at the destination is 44/14.5 or 3.0. These values indicate that this lift would be hazardous for a majority

of healthy industrial workers.

3.2.1.4. Redesign Suggestions

The worksheet shown in [Figure 6](#) indicates that the smallest multipliers (i.e., the greatest penalties) are .44 for the HM, .75 for the VM at the destination, and .86 for the DM. Using [Table 8](#), the following job modifications are suggested:

1. Bring the object closer to the worker at the destination to increase the HM value.
2. Lower the destination of the lift to increase the VM value.
3. Reduce the vertical travel distance between the origin and the destination of the lift to increase the DM value.
4. Modify the job so that significant control of the object at the destination is not required. This will eliminate the need to use the lower RWL value at the destination.

If the operator could load the machine from the side, rather than the from the front, the reel could be turned 90 degrees which would reduce the horizontal location of the hands at the origin (i.e., $H = 10$ inches) and destination of the lift (i.e., $H = 12$ inches). The grip, however, would be poor because the object is bulky and hard to handle and the fingers could not be flexed near 90 degrees when picking up the reel (see [Table 6](#), Note 4).

The RWL and corresponding LI values for this preferred combination of task variables (i.e., loading the machine from the side) are shown on the modified job analysis sheet ([Figure 7](#)). At the origin, the RWL is 35.1 lb. and the LI is 1.3. At the destination, the RWL is 24.6 lb. and the LI is 1.8. Since the LI is still greater than 1.0, however, a more comprehensive solution may be needed. This could include: (1) lowering the vertical height of the destination, which would increase the VM and the DM at both the origin and the destination of the lift; (2) reducing the size and/or weight of the supply reel; (3) transferring the supply reel from the storage area on a mobile, mechanical lifting device or jack that could be moved near the machine to eliminate the need for manual lifting. If it is not feasible to eliminate or redesign the job, then other measures, such as assigning two or more workers, could be considered as an interim control procedure.

3.2.1.5. Comments

Although ergonomic redesign is preferred, this example demonstrates how a change in work practices (i.e., insuring that the operator can load the reel from the side) can reduce the magnitude of physical stress associated with a manual lifting task. This approach, however, relies more on worker compliance than on physical job modifications.

3.2.2. Loading Supply Rolls, Example 2

3.2.2.1. Job Description

With both hands directly in front of the body, a worker lifts the core of a 35-lb roll of paper from a cart, and then shifts the roll in the hands and holds it by the sides to position it on a machine, as shown in [Figure 8](#). Significant control of the roll is required at the destination of the lift. Also, the worker must crouch at the destination of the lift to support the roll in front of the body, but does not have to twist.

3.2.2.2. Job Analysis

The task variable data are measured and recorded on the job analysis worksheet ([Figure 9](#)). The vertical location of the hands is 27 inches at the origin and 10 inches at the destination. The horizontal location of the hands is 15 inches at the origin and 20 inches at the destination. The asymmetric angle is 0 degrees at both the origin and the destination, and the frequency is 4

lifts/shift (i.e., less than .2 lifts/min for less than 1 hour - see [Table 5](#)).

Using [Table 6](#), the coupling is classified as poor because the worker must reposition the hands at the destination of the lift and they can not flex the fingers to the desired 90 degrees angle (e.g., hook grip). No asymmetric lifting is involved (i.e., $A = 0$), and significant control of the object is required at the destination of the lift. Thus, the RWL should be computed at both the origin and the destination of the lift. The multipliers are computed from the lifting equation or determined from the multiplier tables ([Table 1](#), [Table 2](#), [Table 3](#), [Table 4](#), [Table 5](#) and [Table 7](#)). As shown in [Figure 9](#), the RWL for this activity is 28.0 lb. at the origin and 18.1 lb. at the destination.

3.2.2.3. Hazard Assessment

The weight to be lifted (35 lb) is greater than the RWL at both the origin and destination of the lift (28.0 lb and 18.1 lb, respectively). The LI at the origin is 35 lb./28.0 lb. or 1.3, and the LI at the destination is 35 lb./18.1 lb. or 1.9. These values indicate that this job is only slightly stressful at the origin, but moderately stressful at the destination of the lift.

3.2.2.4. Redesign Suggestions

The first choice for reducing the risk of injury for workers performing this task would be to adapt the cart so that the paper rolls could be easily pushed into position on the machine, without manually lifting them.

If the cart cannot be modified, then the results of the equation may be used to suggest task modifications. The worksheet displayed in [Figure 9](#) indicates that the multipliers with the smallest magnitude (i.e., those providing the greatest penalties) are .50 for the HM at the destination, .67 for the HM at the origin, .85 for the VM at the destination, and .90 for the CM value. Using [Table 8](#), the following job modifications are suggested:

1. Bring the load closer to the worker by making the roll smaller so that the roll can be lifted from between the worker's legs. This will decrease the H value, which in turn will increase the HM value.
2. Raise the height of the destination to increase the VM.
3. Improve the coupling to increase the CM.

If the size of the roll can not be reduced, then the vertical height (V) of the destination should be increased. [Figure 10](#) shows that if V was increased to about 30 inches, then VM would be increased from .85 to 1.0; the H value would be decreased from 20 inches to 15 inches, which would increase HM from .50 to .67.; the DM would be increased from .93 to 1.0. Thus, the final RWL would be increased from 18.1 lb. to 30.8 lb., and the LI at the destination would decrease from 1.9 to 1.1.

In some cases, redesign may not be feasible. In these cases, use of a mechanical lift may be more suitable. As an interim control strategy, two or more workers may be assigned to lift the supply roll.

3.2.2.5. Comments

The horizontal distance (H) is a significant factor that may be difficult to reduce because the size of the paper rolls may be fixed. Moreover, redesign of the machine may not be practical. Therefore, elimination of the manual lifting component of the job may be more appropriate than job redesign.

3.2.3. Loading Bags Into A Hopper, Example 3

3.2.3.1. Job Description

The worker positions himself midway between the handtruck and the mixing hopper, as illustrated in [Figure 11](#). Without moving his feet, he twists to the right and picks up a bag off the handtruck. In one continuous motion he then twists to his left to place the bag on the rim of the hopper. A sharp edged blade within the hopper cuts open the bag to allow the contents to fall into the hopper. This task is done infrequently (i.e., 1-12 times per shift) with large recovery periods between lifts (i.e., > 1.2 Recovery Time/Work Time ratio). In observing the worker perform the job, it was determined that the non-lifting activities could be disregarded because they require minimal force and energy expenditure.

Significant control is not required at the destination, but the worker twists at the origin and destination of the lift. Although several bags are stacked on the hand truck, the highest risk of overexertion injury is associated with the bag on the bottom of the stack; therefore, only the lifting of the bottom bag will be examined. Note, however, that the frequency multiplier is based on the overall frequency of lifting for all of the bags.

3.2.3.2. Job Analysis

The task variable data are measured and recorded on the job analysis worksheet ([Figure 12](#)). The vertical location of the hands is 15 inches at the origin and 36 inches at the destination. The horizontal location of the hands is 18 inches at the origin and 10 inches at the destination. The asymmetric angle is 45° at the origin and 45° at the destination of the lift, and the frequency is less than .2 lifts/min for less than 1 hour (see [Table 5](#)).

Using [Table 6](#), the coupling is classified as fair because the worker flex the fingers about 90 degrees and the bags are semi-rigid (i.e., they do not sag in the middle). Significant control of the object is not required at the destination of the lift so the RWL is computed only at the origin. The multipliers are computed from the lifting equation or determined from the multiplier tables ([Table 1](#), [Table 2](#), [Table 3](#), [Table 4](#), [Table 5](#) and [Table 7](#)). As shown in [Figure 12](#), the RWL for this activity is 18.9 lb..

3.2.3.3. Hazard Assessment

The weight to be lifted (40 lb.) is greater than the RWL (18.9 lb.). Therefore, the LI is $40/18.9$ or 2.1. This job would be physically stressful for many industrial workers.

3.2.3.4. Redesign Suggestions

The worksheet shows that the smallest multipliers (i.e., the greatest penalties) are .56 for the HM, .86 for the AM, and .89 for the VM. Using [Table 8](#), the following job modifications are suggested:

1. Bringing the load closer to the worker to increase the HM.
2. Reducing the angle of asymmetry to increase AM. This could be accomplished either by moving the origin and destination points closer together or further apart.
3. Raising the height at the origin to increase the VM.

If the worker could get closer to the bag before lifting, the H value could be decreased to 10 inches, which would increase the HM to 1.0, the RWL would be increased to 33.7 lb., and the LI would be decreased to 1.2 (i.e., $40/33.7$).

3.2.3.5. Comments

This example demonstrates that certain lifting jobs may be evaluated as a single-task or multi-task job. In this case, only the most stressful component of the job was evaluated. For repetitive lifting

jobs, the multi-task approach may be more appropriate. (See Examples 7-10).

3.3. Single Task, Performed Repetitively

3.3.1. Package Inspection, Example 4

3.3.1.1. Job Description

The job illustrated in [Figure 13](#) consists of a worker inspecting compact containers for damage on a low shelf, and then lifting them with both hands directly in front of the body from shelf 1 to shelf 2 at a rate of 3/min for a duration of 45 minutes. For this analysis, assume that (1) the worker cannot take a step forward when placing the object at the destination, due to the bottom shelf, and (2) significant control of the object is required at the destination. The containers are of optimal design, but without handles (For classification, refer to [Table 6](#)).

3.3.1.2. Job Analysis

The task variable data are measured and recorded on the task analysis worksheet ([Figure 14](#)). The horizontal distance at the origin of the lift is 10 inches and the horizontal distance at the destination of the lift is 20 inches. The height of shelf one is 22 inches and the height of shelf two is 59 inches. Since the container is of optimal design, but does not have handles or handhold cutouts, the coupling is defined as "fair" (see [Table 6](#)). No asymmetric lifting is involved (i.e., $A = 0$). Significant control of the load is required at the destination of the lift. Therefore, the RWL is computed at both the origin and the destination of the lift.

The multipliers are computed from the lifting equation or determined from the multiplier tables ([Table 1](#), [Table 2](#), [Table 3](#), [Table 4](#), [Table 5](#) and [Table 7](#)). As shown in [Figure 14](#), the RWL for this activity is 34.9 lb. at the origin and 15.2 lb. at the destination.

3.3.1.3. Hazard Assessment

The weight to be lifted (26 lb.) is less than the RWL at the origin (34.9 lb.) but greater than the RWL at the destination (15.2 lb.). The LI is $26/34.9$ or .76 (rounded to .8) at the origin, and the LI is $26/15.2$ or 1.7 at the destination. These values indicate that the destination of the lift is more stressful than the origin, and that some healthy workers would find this task physically stressful.

3.3.1.4. Redesign Suggestions

The worksheet illustrated in [Figure 14](#) shows that the multipliers with the smallest magnitude (i.e., those that provide the greatest penalties) are .50 for the HM at the destination, .78 for the VM, .87 for the DM, and .88 for the FM at the destination of the lift. Using [Table 8](#), the following job modifications are suggested:

1. Bring the destination point closer to the worker to increase the HM value.
2. Lower the height of shelf 2 to increase the VM value.
3. Decrease the vertical distance between origin and destination of lift to increase the DM value.
4. Reduce the lifting frequency rate to increase the FM value.
5. Modify the task so that there is no need for significant control of the object at the destination to eliminate the lower RWL value.

Practical job modifications could include bringing shelf 2 closer to the worker to reduce H, raising the height of shelf 1 to increase the CM value, lowering the height of shelf 2 to reduce D, or reducing the need for significant control at the end of the lift by providing a receiving chute.

3.3.1.5. Comments

Since the lifting pattern is continuous over the 45 minute work session, the lifting frequency is not adjusted using the special procedure described on page 27.

3.3.2. Dish-Washing Machine Unloading, Example 5

3.3.2.1. Job Description

A worker manually lifts trays of clean dishes from a conveyor at the end of a dish washing machine and loads them on a cart as shown in [Figure 15](#). The trays are filled with assorted dishes (e.g., glasses, plates, bowls) and silverware. The job takes between 45 minutes and 1 hour to complete, and the lifting frequency rate averages 5 lifts/min. Workers usually twist to one side of their body to lift the trays (i.e., asymmetric lift) and then rotate to the other side of their body to lower the trays to the cart in one smooth continuous motion. The maximum amount of asymmetric twist varies between workers and within workers, however, there is usually equal twist to either side. During the lift the worker may take a step toward the cart. The trays have well designed handhold cutouts and are made of lightweight materials.

3.3.2.2. Job Analysis

The task variable data are measured and recorded on the job analysis worksheet ([Figure 16](#)). At the origin of the lift, the horizontal distance (H) is 20 inches, the vertical distance (V) is 44 inches, and the angle of asymmetry (A) is 300. At the destination of the lift, H is 20 inches, V is 7 inches, and A is 300. The trays normally weigh from 5 lb. to 20 lb., but for this example, assume that all of the trays weigh 20 lb..

Using [Table 6](#), the coupling is classified as Good. Significant control is required at the destination of the lift. Using [Table 5](#), the FM is determined to be .80. As shown in [Figure 16](#), the RWL is 14.4 lb. at the origin and 13.3 lb. at the destination.

3.3.2.3. Hazard Assessment

The weight to be lifted (20 lb.) is greater than the RWL at both the origin and destination of the lift (14.4 lb. and 13.3 lb., respectively). The LI at the origin is $20/14.4$ or 1.4 and the LI at the destination is 1.5. These results indicate that this lifting task would be stressful for some workers.

3.3.2.4. Redesign Suggestions

The worksheet shows that the smallest multipliers (i.e., the greatest penalties) are .50 for the HM, .80 for the FM, .83 for the VM, and .90 for the AM. Using [Table 8](#), the following job modifications are suggested:

1. Bring the load closer to the worker to increase HM.
2. Reduce the lifting frequency rate to increase FM.
3. Raise the destination of the lift to increase VM.
4. Reduce the angle of twist to increase AM by either moving the origin and destination closer together or moving them further apart. Since the horizontal distance (H) is dependent on the width of the tray in the sagittal plane, this variable can only be reduced by using smaller trays. Both the DM and VM, however, can be increased by lowering the height of the origin and increasing the height of the destination. For example, if the height at both the origin and destination is 30 inches, then VM and DM are 1.0, as shown in the modified worksheet ([Figure 17](#)). Moreover, if the cart is moved so that the twist is eliminated, the AM can be increased from .90 to 1.00. As shown in [Figure 17](#), with these redesign

suggestions the RWL can be increased from 13.3 lb. to 20.4 lb., and the LI values are reduced to 1.0.

3.3.2.5. Comments

This analysis was based on a one-hour work session. If a subsequent work session begins before the appropriate recovery period has elapsed (i.e., 1.2 hours), then the eight-hour category would be used to compute the FM value.

As in the previous example, since the lifting pattern is continuous over the full duration of the work sample (i.e., more than 15 minutes), the lifting frequency is not adjusted using the special procedure described on page 27.

3.3.3. Product Packaging I, Example 6

3.3.3.1. Job Description

In the job illustrated in [Figure 18](#), products weighing 25 lb. arrive via a conveyor at a rate of 1-per minute, where a worker packages the product in a cardboard box and then slides the packaged box to a conveyor behind table B. Assume that significant control of the object is not required at the destination, but that the worker twists to pick up the product; also assume that the worker can flex the fingers to the desired 90 degrees angle to grasp the container. The job is performed for a normal 8-hour shift, including regular rest allowance breaks.

3.3.3.2. Job Analysis

The task variable data are measured and recorded on the job analysis worksheet ([Figure 19](#)). At the origin, the vertical location (V) is 24 inches and the horizontal location is 14 inches. At the destination, the vertical location is 40 inches, which represents the height of table B plus the height of the box, and the horizontal location is 16 inches.

Using [Table 6](#), the coupling is classified as fair. The worker twists 90 degrees to pick up the product. The job is performed for an 8-hour shift with a frequency rate of 1-lift per minute. Using [Table 5](#), the FM is determined to be .75. Since significant control is not required at the destination, then the RWL is only computed at the origin of the lift. The multipliers are computed from the lifting equation or determined from the multiplier tables ([Table 1](#), [Table 2](#), [Table 3](#), [Table 4](#), [Table 5](#) and [Table 7](#)). As shown in [Figure 19](#), the RWL for this lifting task is 16.4 lb..

3.3.3.3. Hazard Assessment

The weight to be lifted (25 lb.) is greater than the RWL (16.4 lb.). Therefore, the LI is 25/16.4 or 1.5. This task would be stressful for some healthy workers.

3.3.3.4. Redesign Suggestions

The worksheet shows that the multipliers with the smallest magnitude (i.e., those providing the greatest penalties) are .71 for the HM, .71 for the AM, and .75 for the FM. Using [Table 8](#), the following job modifications are suggested:

1. Bring the load closer to the worker to increase HM.
2. Move the lift's origin and destination closer together to reduce the angle of twist and increase the AM.
3. Reduce the lifting frequency rate and/or provide longer recovery periods to increase FM.

Assuming that the large horizontal distance is due to the size of the object lifted rather than the

existence of a barrier, then the horizontal distance could only be reduced by making the object smaller or re-orienting the object. An alternate approach would be to eliminate body twist by providing a curved chute to bring the object in front of the worker. For this modified job (worksheet shown in [Figure 20](#)), the AM is increased from 0.71 to 1.0, the HM is increased from 0.71 to 0.77, the RWL is increased from 16.4 lb. to 25 lb., and the LI is decreased from 1.5 to 1.00. Eliminating body twist reduces the physical stress to an acceptable level for most workers. Alternate redesign recommendations could include: (1) raising the height of conveyor A and/or reducing the height of work bench B; or, (2) Providing good couplings on the containers. For example, the curved chute could also be designed to bring the load to a height of 30 inches. This would increase the VM, DM, and CM values to 1.0, which would reduce the lifting index even further.

3.3.3.5. Comments:

Although several alternate redesign suggestions are provided, reducing the asymmetric angle should be given a high priority because a significant number of overexertion lifting injuries are associated with excessive lumbar rotation and flexion.

As in the earlier examples, the lifting pattern is continuous over the full duration of the work sessions. Thus, the lifting frequency is not adjusted using the special procedure described in the Frequency Component section on page 27.

3.4. Repetitive Multi-Task, Short-Duration

3.4.1. Depalletizing Operation, Example 7

3.4.1.1. Job Description

A worker unloads 12-lb cartons from a pallet onto a conveyor, as illustrated in [Figure 21](#). The cartons are vertically stacked from the floor in five tiers. No twisting is required when picking up and putting down the cartons, and the worker is free to step on the pallet to get close to each carton (i.e., only one layer in depth from the front of the pallet must be analyzed). Walking and carrying are minimized by keeping the pallets close to the conveyor, and significant control of the object is not required at the destination of the lift. The vertical location (V) at the origin, horizontal location (H), and vertical travel distance (D), vary from one lift to the next.

3.4.1.2. Job Analysis

Since the job consists of more than one distinct task and the task variables often change, the multi-task lifting analysis procedure should be used.

This job is divided into five tasks represent pallets. Task numbering is arbitrary and the sequencing does not reflect the order in which the tasks are performed. It is important, however, to identify each distinct type of lifting task. Note, it may not be appropriate to use the lifting equation for mixed-task jobs that require significant amounts of pushing, pulling, or carrying.

The following measurements/observations were made and recorded on the job analysis worksheet ([Figure 22](#)):

1. Carton dimensions are 16 inches x 16 inches x 16 inches.
2. The vertical locations at the origin represent the position of the hands under the cartons. The top of the conveyor is 20 inches from the floor.

3. For this example, assume that the horizontal locations were not measured, but estimated using the formulas provided in the Horizontal Multiplier section on page 14. From these formulas, $H = (8 + 16/2)$ or 16 inches for the top four tiers and $H = (10 + 16/2)$ or 18 inches for the bottom tier.
4. The pallet is 4 inches in height.
5. No asymmetric lifting is involved (i.e., $A = 0$).
6. Cartons are continuously unloaded at the rate of 12-per minute (i.e, 2.4 lifts/min per tier) for 1 hour.
7. The job consists of continuous 1-hour work sessions separated by 90-minute recovery periods.
8. Using [Table 6](#), the coupling is classified as fair.

The multi-task lifting analysis consists of the following three steps:

1. Compute the frequency-independent-RWL (FIRWL) and frequency-independent-lifting index (FILI) values for each task using a default FM of 1.0.
2. Compute the single-task-RWL (STRWL) and single-task-lifting index (STLI) for each task. Note, in this example, interpolation was used to compute the FM value for each task because the lifting frequency rate was not a whole number (i.e., 2.4).
3. Renumber the tasks in order of decreasing physical stress, as determined from the STLI value, starting with the task with the largest STLI.

Step 1

Compute the FIRWL and FILI values for each task using a default FM of 1.0. The multi-task lifting analysis consists of the following three steps:

1. Compute the frequency-independent-RWL (FIRWL) and frequency- independent- lifting index (FILI) values for each task using a default FM of 1.0.

	FIRWL	FILI
	-----	-----
Tier 1	20.4 lbs	.6
Tier 2	28.4 lbs	.4
Tier 3	28.7 lbs	.4
Tier 4	23.8 lbs	.5
Tier 5	19.9 lbs	.6

These results indicate that none of the tasks are particularly stressful, from a strength point of view, but that tiers 1 and 5 do require the most strength. Remember, however, that these results do not take the frequency of lifting into consideration.

Step 2

Compute the STRWL and STLI values for each task, where $STRWL = FIRWL \times FM$. The FM for each task is determined by interpolating between the FM values for 2 and 3 lifts/minute from Column 2 of [Table 5](#). The results are displayed in [Figure 22](#).

	STRWL	STLI
	-----	-----
Tier 1	18.4 lbs	.7
Tier 2	25.6 lbs	.5
Tier 3	25.8 lbs	.5
Tier 4	21.4 lbs	.6
Tier 5	17.9 lbs	.7

These results suggest that none of the tasks are stressful, if performed individually. Note, however, that these values do not consider the combined effects of all of the tasks.

Step 3

Renumber the tasks, starting with the task with the largest STLI value, and ending with the task with the smallest STLI value. If more than one task has the same STLI value, assign the lower task number to the task with the highest frequency.

3.4.1.3. Hazard Assessment

Compute the composite-lifting index (CLI) for the job, using the renumbered tasks as described in the Multi-Task procedures on page 43.

As shown on [Figure 22](#), the CLI value for this job is 1.4. This means that some healthy workers would find this job physically stressful. Therefore, some redesign may be needed. Analysis of the results suggest that any three of these tasks would probably result in a CLI below 1.0, which would be acceptable for nearly all healthy workers. However, when the other two tasks are added, the overall frequency increases the lifting index above 1.0. This suggests that the overall frequency should be reduced to limit the physical stress associated with this job.

3.4.1.4. Redesign Suggestions

The worksheet illustrated in [Figure 22](#) indicates that the multipliers with the smallest magnitude (i.e., those providing the greatest penalties) are .56 for the HM at Tier 1; .63 for the HM at Tiers 2 through 5; .72 for the VM at Tier 5; and .81 for the VM at Tier 1. Using [Table 8](#), the following job modifications are suggested:

1. Bring the cartons closer to the worker to increase the HM value.
2. Lower the height for Tier five to increase the VM value.
3. Raise the height of tier one to increase the VM value.

The FILI values are all less than 1.0, indicating that strength should not be a problem for any of these tasks. Moreover, the STLI were all less than 1.0, indicating that none of the tasks would be physically stressful, if performed individually. When the combined physical demands of the tasks are considered, however, the resulting CLI exceeds 1.0. This is likely due to the high frequency rate for the combined job. Since a number of simplifying assumptions were made in this example, however, a more detailed metabolic analysis of such a job may be needed before implementing ergonomic redesign. Such an analysis is described in detail by Garg et al. (1978).

An engineering approach should be the first choice for job redesign (i.e., physical changes in layout, such as raising or lowering shelves, tables, or pallets) rather than worker compliance. In this case, the high frequency rate is a significant problem and should be reduced. A reduction in

frequency could decrease the CLI to about 1.0.

3.4.1.5. Comments

With more complicated tasks, such a simple solution will not necessarily be possible, and more detailed analyses may be required to determine compressive forces, strength requirements, and energy expenditures.

3.4.2. Handling Cans of Liquid, Example 8

3.4.2.1. Job Description

A worker unloads cans of liquids from a cart to three storage shelves as shown in [Figure 23](#). Although the cans are lifted in the sagittal plane when moved between shelves, they are usually lifted asymmetrically, from one side of the body to the other, when lifted from the cart to the shelves. The worker may take a step when placing the cans onto the shelf. The cans do not have molded handholds, so the worker hooks his fingers or slides his hand under the turned edge of the can to lift it. When lifting to the top shelf, workers usually reposition their grip near the end of the lift. The work pattern consists of intermittent, six-minute work sessions separated by three-minute recovery periods. The actual lifting frequency during the six-minute work sessions was 9 lifts/minute. There is a 90-minute break after each hour of work.

3.4.2.2. Job Analysis

Since the job consists of more than one distinct task and the task variables change often, the multi-task lifting analysis procedure should be used.

This job is divided into three tasks. Task 1 is defined as lifting from the cart to the lower shelf. Task 2 is defined as lifting to the center shelf, and Task 3 is defined as lifting to the upper shelf. Since task 3 requires a reposition of grip at the destination, it must be analyzed at both the origin (Task 3a) and the destination of the lift (Task 3b). The left and right shelf positions are considered to be equivalent, since the worker can step toward the shelf during the lift.

The following task variable data were measured and recorded on the job analysis worksheet ([Figure 24](#)):

1. Cans are 8 inches in height.
2. Cart is 15 inches high.
3. Shelf 1 is 2 inches high.
4. Shelf 2 is 22 inches high.
5. Shelf 3 is 42 inches high.
6. At the origin, the horizontal distance (H) is 17 inches, the vertical height (V) is 23 inches, and the angle of asymmetry (A) is 45° for all lifts.
7. At the destination, H is 22 inches, and A is 45° for all lifts.
8. The cans are lifted in an intermittent work pattern at a rate of 9 lifts/min (i.e., 3 lifts/min per shelf) for a duration of 1 hour.

9. Using [Table 6](#), the couplings are classified as poor.

The multi-task lifting analysis consists of the following three steps:

1. Compute the frequency-independent-RWL (FIRWL) and frequency-independent-lifting index (FILI) values for each task using a default FM of 1.0.
2. Compute the single-task-RWL (STRWL) and single-task-lifting index (STLI) for each task. Note: Since the work pattern is not continuous for the 15-minute sample, the lifting frequency is adjusted using the special procedure described on page 27.
3. Renumber the tasks in order of decreasing physical stress, as determined from the STLI value, starting with the task with the largest STLI.

Step 1

Compute the FIRWL and FILI values for each task using a default FM of 1.0. The other multipliers are computed from the lifting equation or determined from the multiplier tables ([Table 1](#), [Table 2](#), [Table 3](#), [Table 4](#), [Table 5](#), and [Table 7](#)). The FIRWL and FILI values are computed only at the origin for Tasks 1 and 2, but since significant control is required for Task 3, the values must be computed at both the origin and destination of the lift.

	FIRWL	FILI
	-----	-----
Task 1	21.2 lbs	1.4
Task 2	22.1 lbs	1.4
Task 3a	19.7 lbs	1.5
Task 3b	13.7 lbs	2.2

These results indicate that all of the tasks may require considerable strength, especially at the destination of Task 3. Remember, however, that these results do not take the frequency of lifting into consideration.

Step 2

Compute the STRWL and STLI values for each task, where the STRWL for a task is equivalent to the product of the FIRWL and the FM for that task. In this example, the work pattern is intermittent so the frequency is adjusted using the special procedure. Thus, for this job, $F = (3 \text{ lifts/minute} \times 6 \text{ minutes/period} \times 2 \text{ periods}) / 15 \text{ minutes}$, which is equal to 36/15, or 2.4 lifts/minute. As in the previous example, the FM values must be determined by interpolating between the FM values for 2 and 3 lifts/minute from Column 2 of [Table 5](#). The results are displayed in [Figure 24](#) and summarized below.

	STRWL	STLI
	-----	-----
Task 1	19.1 lbs	1.6
Task 2	19.9 lbs	1.5
Task 3a	17.7 lbs	1.7
Task 3b	12.4 lbs	2.4

These results indicate that all of the tasks would be particularly stressful, if performed individually.

Note, however, that these values do not consider the combined effects of all of the tasks.

Step 3

Renumber the tasks, starting with the task with the largest STLI value, and ending with the task with the smallest STLI value. If more than one task has the same STLI value, assign the lower task number to the task with the highest frequency.

3.4.2.3. Hazard Assessment

Compute the composite-lifting index (CLI) using the renumbered tasks. Recall that a special procedure is used to determine the appropriate FM values when (1) repetitive lifting is performed for short durations, and (2) sufficient recovery periods are provided. For example, the frequency for each task in this example is determined by multiplying the actual frequency rate (3 lifts per minute) times the duration (12 minutes), and dividing the result by 15 minutes to obtain an adjusted frequency rate of 2.4 lifts per minute, which is used to compute the CLI.

As shown in [Figure 24](#), the CLI for this job is 2.9, which indicates that there is a significant level of physical stress associated with this job. It appears that strength is a problem for all three tasks, since the FILI values all exceed 1.0. Therefore, the overall physical demands of the job are primarily the result of excessive strength demands, rather than the lifting frequency rate. This may not be the case if the duration exceeds 15 minutes, due to an increase in endurance demands.

3.4.2.4. Redesign Suggestions

The worksheet illustrated in [Figure 24](#) shows that the multipliers with the smallest magnitude (i.e., those providing the greatest penalties) are .46 for the HM for Task 3 at the destination; .59 for the HM for Tasks 1, 2, and 3 at the origin; .85 for the VM for Task 3 at the destination; .86 for the AM for all tasks at the origin and destination; and, .90 for the CM for all tasks.

Using [Table 8](#), the following job modifications are suggested:

1. Bring the load closer to the worker to increase HM by reducing the size of the can and/or bringing the load between the worker's legs.
2. Reduce the angle of twist to increase AM by moving the origin and destination closer together or further apart.
3. Provide containers with handles or handhold cutouts to increase CM.
4. Raise the origin of the lift to increase VM.

Raising the vertical height at the origin would also decrease the vertical displacement (D), and reduce the angle of twist. Since the size of the H value at the origin depends on the size of the container, the only way to reduce H would be to reduce the container size. An additional benefit of reducing container size is an accompanying reduction in H at the destination for Task 3.

If (1) the height of the cart is increased, (2) twisting is eliminated, and (3) Task 3 is deleted, then the FIRWL for Tasks 1 and 2 would be 27.1 lb. (i.e., $51 \times .59 \times 1.0 \times 1.0 \times 1.0 \times 1.0 \times 0.90$), and the FILI would be reduced from 1.4 to 1.1, which would be acceptable to many more workers than before.

As an alternative, an engineering modification could include a design that allows the shelves to either revolve vertically or rotate horizontally for more storage space at the optimum lifting height of 30 inches. This design would eliminate the need to bend or reach while lifting, which is a safer design.

3.4.2.5. Comments

In this example, the cans were not stacked higher than a single can on the cart. The cans, however, could be stacked higher. For a second layer, the vertical height (V) at the origin would be near knuckle height (i.e., about 31 inches). The vertical multiplier (VM) would be increased and the FIRWL would be higher than for lifting from the lowest layer, thus reducing the risk. A third layer, however, may increase the risk of overexertion injury and result in a more stressful job for some workers.

3.5. Repetitive Multi-Task, Long-Duration (> 2 hrs)

3.5.1. Product Packaging II, Example 9

3.5.1.1. Job Description

Rolls of paper weighing 25 lbs each are pulled off a moving conveyor to work stations where they are wrapped and placed in boxes, as shown in [Figure 25](#). Conveyor delivery allows the roll to slide to the wrapping area, but the roll must be manipulated as it is wrapped. After wrapping, the roll is lifted from the table and placed in a box. The box is closed, secured, and lifted to a pallet. The worker completes this operation once per minute for a continuous duration of 8 hours. The worker does not twist when lifting the rolls of paper. The first lift (from the table to the box) requires significant control at the destination. The second lift (from box to pallet) does not require significant control at the destination.

3.5.1.2. Job Analysis

Since the job consists of more than one task, the multi-task lifting analysis procedure should be used. Task 1 consists of lifting the roll of paper from the table and placing it into a cardboard box, and Task 2 consists of lifting the loaded box from the floor onto the pallet. No asymmetric lifting is involved in either task (i.e., A = 0). The following task variable data were measured and recorded on the job analysis worksheet ([Figure 26](#)).

Task 1:

1. At the origin of the lift, the horizontal distance (H) is 21 inches and the vertical distance (V) is 38 inches.
2. At the destination of the lift, H is 10 inches and V is 36 inches.
3. If the rolls are handled lengthwise, as shown in [Figure 25](#), then the couplings are classified as "poor", because the fingers can't be flexed near 90 degrees. (See [Table 6](#)).

Task 2:

1. At the origin of the lift, H is 10 inches and V is 0 inches.
2. At the destination of the lift, H is 10 inches and V is 6 inches.
3. The couplings are classified as "fair" because the fingers can be flexed under the box about 90 degrees (See [Table 6](#)).

The lifting frequency rate for each task is 1 lift/minute. This means that two lifts occur each minute, since both Task 1 and Task 2 occur about once per minute.

The multi-task lifting analysis consists of the following three steps:

1. Compute the frequency-independent-RWL (FIRWL) and frequency-independent-lifting index (FILI) values for each task using a default FM of 1.0.
2. Compute the single-task-RWL (STRWL) and single-task-lifting index (STLI) for each task.
3. Renumber the tasks in increasing order of physical stress, as determined from the STLI value, starting with the task with the largest STLI.

Step 1

Compute the FIRWL and FILI values for each task using a default FM of 1.0. The other multipliers are computed from the lifting equation or determined from the multiplier tables ([Table 1](#), [Table 2](#), [Table 3](#), [Table 4](#), [Table 5](#), and [Table 7](#)). Since Task 1 requires significant control at the destination, the FIRWL value must be calculated at both the origin (Task 1a) and the destination (Task 1b) of the lift.

	FIRWL	FILI
	-----	-----
Task 1a	20.7 lbs	1.2
Task 1b	44.1 lbs	.6
Task 2	37.8 lbs	.7

The results indicate that these tasks should not require excessive strength. Remember, however, that these results do not take the frequency of lifting into consideration.

Step 2

Compute the STRWL and STLI values for each task, where the STRWL for a task is equivalent to the product of the FIRWL and the FM for that task. Based on the given frequencies, vertical heights, and durations, the FM values are determined from [Table 5](#).

The results are displayed in [Figure 26](#) and summarized below.

	STRWL	STLI
	-----	-----
Task 1a	15.5 lbs	1.6
Task 1b	33.1 lbs	.8
Task 2	28.4 lbs	.9

These results indicate that, if performed individually, Task 2 would not be stressful, but that Task 1 would be stressful for some healthy workers. Note, however, that these values do not consider the combined effects of all of the tasks.

Step 3

Renumber the tasks, starting with the task with the largest STLI value, and ending with the task with the smallest STLI value. If more than one task has the same STLI value, assign the lower task number to the task with the highest frequency.

3.5.1.3. Hazard Assessment

Compute the composite-lifting index (CLI) using the renumbered tasks. Only the origin or destination component with the largest STLI is used to compute the CLI for the job when significant control is required for a task. As shown in [Figure 26](#), the CLI for this job is 1.7, which indicates that this job would be physically stressful for some healthy workers.

3.5.1.4. Redesign Suggestions

The worksheet illustrated in [Figure 26](#) shows that the multipliers with the smallest magnitude (i.e., those providing the greatest penalties) for this task are .48 for the HM at the origin of Task 1, .78 for the VM for Task 2, and .90 for the CM at the origin and destination of Task 1. Using [Table 8](#), the following job modifications are suggested:

1. Bring the load closer to the worker to increase HM by reducing the size of the roll and/or bringing the load between the worker's legs at the origin for Task 1.
2. Raise the vertical height of the lift for Task 2 at the origin and at the destination to increase VM.
3. Provide better couplings for Task 1 to increase CM

The largest penalty comes from lifting the rolls from the wrapping table into the box. A practical job redesign would be to provide a recess for the box at the end of the table, so that the worker could easily slide the roll into the box without lifting it. The worker could then slide the box to the edge of the table, and lift it from the table to the pallet. This job modification would allow the worker to get closer to the load when lifting, which would increase the FIRWL and decrease the FILI.

As an alternative job modification, the worker could be rotated from this job to a job with light work every one to two hours to decrease the lifting duration. This would provide a sufficient recovery period for the worker, so that fatigue would not become a problem. The light duty work, however, should last for at least .3 times the amount of time spent on the packaging job.

3.5.1.5. Comments

There is an inherent danger in trying to simplify a complex lifting job. The overriding concern is that the worker is not exposed to excessive biomechanical or physiological stress. This multi-task analysis procedure was designed to provide a series of intermediate values that would help guide the redesign of physically demanding lifting tasks. These values include the FIRWL, FILI, STRWL, and STLI. These intermediate values should not be used as design limits, since they only provide task specific information. The overall risk of injury for a lifting job is dependent upon the combined effects of the job, rather than the individual effects of the tasks.

3.5.2 Warehouse Order Filling, Example 10

3.5.2.1. Job Description

A worker lifts cartons of various sizes from supply shelves onto a cart as illustrated in [Figure 27](#). There are three box sizes (i.e., A, B, and C) of various weights. These lifting tasks are typical in warehousing, shipping, and receiving activities in which loads of varying weights and sizes are lifted at different frequencies. Assume that the following observations were made: (1) control of the load is not required at the destination of any lift; (2) the worker does not twist when picking up and putting down the cartons; (3) the worker can get close to each carton; and, (4) walking and carrying are minimized by keeping the cart close to the shelves.

3.5.2.2. Job Analysis

Since the job consists of more than one distinct task and the task variables often change, the multi-task lifting analysis procedure should be used.

This job can be divided into three tasks represented by cartons A, B, and C. The following measurements were made and recorded on the job analysis worksheet ([Figure 28](#)):

1. The horizontal locations (H) for each task at the origin and destination are as follows: Box A, 16 inches; Box B, 12 inches; and, Box C, 8 inches.
2. The vertical locations (V) at the origin are taken to be the position of the hands under the cartons as follows: Box A, 0 inches; Box B, 0 inches; and, Box C, 30 inches.
3. The vertical locations (V) at the destination are the vertical position on the cart as follows: Box A, 30 inches; Box B, 6 inches; and, Box C, 39 inches.
4. The average weights lifted for each task are as follows: Box A, 22 lb.; Box B, 33 lb.; and, Box C, 11 lb..
5. The maximum weights lifted for each task are as follows: Box A, 33 lb.; Box B, 44 lb.; and, Box C, 22 lb..
6. No asymmetric lifting is involved (i.e., A = 0).
7. The lifting frequency rates for each task are as follows: Box A, 1 lift/min; Box B, 2 lifts/min; and Box C, 5 lifts/min.
8. The lifting duration for the job is 8 hours, however, the maximum weights are lifted infrequently (i.e., less than or equal to once every 5 minutes for 8 hours).
9. Using [Table 6](#), the couplings are classified as fair.

The multi-task lifting analysis consists of the following three steps:

1. Compute the frequency-independent-RWL (FIRWL) and frequency-independent-lifting index (FILI) values for each task using a default FM of 1.0.
2. Compute the single-task-RWL (STRWL) and single-task-lifting index (STLI) for each task.
3. Renumber the tasks in order of decreasing physical stress, as determined from the STLI value, starting with the task with the largest STLI.

Step 1

Compute the FIRWL and FILI values for each task using a default FM of 1.0. The other multipliers are computed from the lifting equation or determined from the multiplier tables ([Table 1](#), [Table 2](#), [Table 3](#), [Table 4](#), [Table 5](#), and [Table 7](#)). Recall that the FILI is computed for each task by dividing the maximum weight of that task by its FIRWL.

	FIRWL	FILI
Task 1	21.0 lbs	1.6

Task 2	31.4 lbs	1.4
Task 3	51.0 lbs	.4

These results indicate that two of the tasks require strength demands that exceed the RWL level. Remember, however, that these results do not take the frequency of lifting into consideration.

Step 2

Compute the STRWL and STLI values for each task, where the STRWL for a task is equivalent to the product of the FIRWL and the FM for that task. Recall that the STLI is computed for each task by dividing the average weight of that task by its STRWL. The appropriate FM values are determined from [Table 5](#).

	STRWL	STLI
	-----	-----
Task 1	15.8 lbs	1.4
Task 2	20.4 lbs	1.6
Task 3	17.8 lbs	.6

These results indicate that Tasks 1 and 2 would be stressful for some workers, if performed individually. Note, however, that these values do not consider the combined effects of all of the tasks.

Step 3

Renumber the tasks, starting with the task with the largest STLI value, and ending with the task with the smallest STLI value. If more than one task has the same STLI value, assign the lower task number to the task with the highest frequency.

3.5.2.3. Hazard Assessment

Compute the composite-lifting index (CLI) using the renumbered tasks. As shown in [Figure 28](#), the CLI for this job is 3.6, which indicates that this job would be physically stressful for nearly all workers. Analysis of the results suggests that the combined effects of the tasks are significantly more stressful than any individual task.

3.5.2.4. Redesign Suggestions

Developing a redesign strategy for a job depends on tangible and intangible factors that may be difficult to evaluate, including costs/benefits, feasibility, and practicality. No preferred procedure has been developed and tested. Therefore, the following suggestions represent only one approach to ergonomic job modification.

In this example, the magnitude of the FILI, STLI, and CLI values indicate that both strength and endurance would be a problem for many workers. Therefore, the redesign should attempt to decrease the physical demands by modifying the job layout and decrease the physiological demands by reducing the frequency rate or duration of continuous lifting. If the maximum weights were eliminated from the job, then the CLI would be significantly reduced, the job would be less stressful, and more workers could perform the job than before.

Those lifts with strength problems should be evaluated for specific engineering changes, such as (1) decreasing carton size or removing barriers to reduce the horizontal distance; (2) raising or lowering the origin of the lift; (3) reducing the vertical distance of the lift; improving carton

couplings, and 4) decreasing the weight to be lifted. The redesign priority for this example is based on identifying interventions that provide the largest increase in the FIRWL for each task (Step 2 on worksheet). For example, the maximum weight lifted for carton A is unacceptable; however, if the carton at the origin were on the upper shelf, then the FIRWL for Task 1 would increase from 21.0 lbs to 27.0 lbs. The maximum weight lifted still exceeds the FIRWL, but lifts of average weight are now below the FIRWL. Additionally, providing handles, decreasing box size, or reducing the load to be lifted will decrease the stress of manual lifting.

3.5.2.5. Comments

This example demonstrates the complexity of analyzing multi-task lifting jobs. Errors resulting from averaging, and errors introduced by ignoring other factors (e.g., walking, carrying, holding, pushing and pulling activities, and environmental stressors), can only be resolved with detailed biomechanical, metabolic, cardiovascular, and psychophysical evaluations.

Several important application principles are illustrated in this example:

1. The horizontal distance (H) for Task 3 was less than the 10.0 inches minimum. Therefore, H was set equal to 10 inches (i.e., multipliers must be less than or equal to 1.0).
2. The vertical travel distance (D) in Task 2 was less than the 10 inches minimum. Therefore, D was set equal to 10 inches.

GLOSSARY

Action Limit (AL)

A term from the 1981 WPG that denotes the weight limit that nearly all workers can perform safely. The term has been replaced in the 1991 equation with the term Recommended Weight Limit (see RWL).

Angle of Asymmetry (A)

The angle between the Asymmetric Line and the Sagittal Line of the worker's body, as defined by the worker's neutral body position; measure at the origin and destination of lift and use to compute the Asymmetric Multiplier (see Asymmetric Line, Asymmetric Multiplier, and Neutral body position).

Asymmetric Multiplier (AM)

A reduction coefficient defined as $(1 - (.0032A))$, has a maximum value of 1.0 when the load is lifted directly in front of the body and decreases linearly as the Angle of Asymmetry (A) increases.

Asymmetry Line

The auxiliary line that connects the mid-point of the line drawn between the inner ankle bones and the point projected down to the floor directly below the center of the hand grasps.

Composite Lifting Index (CLI)

The term that denotes the overall lifting index for a multi-task manual lifting job.

Coupling Classification

The three-tiered classification of the quality of the coupling between the worker's hands and the object (either good, fair, or poor); used in the Coupling Multiplier (see CM).

Coupling Multiplier (CM)

A reduction coefficient based on the Coupling Classification and Vertical Location of the lift (values

found in [Table 7](#)).

Distance Variable (D)

The vertical travel distance of the hands between the origin and destination of the lift measured in inches or centimeters; used in the Distance Multiplier (see DM).

Distance Multiplier (DM)

A reduction coefficient defined as $(.82 + (1.8/D))$, for D measured in inches, and $(.82 + (4.5/D))$, for D measured in centimeters.

Duration of Lifting

The three-tiered classification (either short, moderate, or long) of lifting duration specified by the distribution of work-time and recovery-time (work pattern).

Frequency of Lifting (F)

The average number of lifts per minute over a 15 minute period; used in the Frequency Multiplier (see FM)

Frequency Multiplier (FM)

A reduction coefficient that depends upon the Frequency of Lifting (F), the Vertical Location (V) at the origin, and the Duration of Lifting (values found in [Table 5](#)).

Frequency-Independent Lifting Index (FILI)

A term defined as $(L)/(FIRWL)$, identifies individual tasks with potential strength problems, values exceeding 1.0 suggest that ergonomic changes may be needed to decrease the strength demands.

Frequency-Independent Recommended Weight Limits (FIRWL)

A value used in a multi-task assessment; product of all the reduction coefficients and the LC, holding FM equal to unity; reflects the overall strength demands for a single repetition of that task; used in Frequency-Independent Lifting Index (see FILI).

Horizontal Location (H)

The horizontal distance between the mid-point of the hand grasps projected down to the floor and the mid-point of the line between the inner ankle bones; used in the Horizontal Multiplier (see HM).

Horizontal Multiplier (HM)

A reduction coefficient defined as $10/H$, for H measured in inches, and $25/H$, for H measured in centimeters.

Lifting Index (LI)

A term defined as L/RWL ; generally relates the level of physical stress associated with a particular manual lifting task to the number of workers who should be able to perform the task (see Load Weight). A value of 1.0 or more denotes that the task is hazardous for some fraction of the population.

Lifting Task

A term denoting the act of manually grasping an object of definable size and mass with two hands, and vertically moving the object without mechanical assistance.

Load Constant (LC)

A constant term in the RWL equation defined as a fixed weight of 23 kg or 51 lb; generally considered the maximum load nearly all healthy workers should be able to lift under optimal conditions (i.e. all the reduction coefficients are unity).

Load Weight (L)

A term defining the weight of the object to be lifted, in pounds or Newtons, including the container; used in the Lifting Index (see LI)

Long-duration

A term defining lifting tasks that have a duration of between two and eight hours with standard industrial rest allowances (e.g., morning, lunch, and afternoon rest breaks).

Moderate-duration

A term defining lifting tasks that have a duration of between one and two hours, followed by a recovery period of at least 0.3 times the work time {i.e., at least a 0.3 recovery-time to work-time ratio (RT/WT)}.

Poor Coupling

A term defining a poor hand-to-object coupling that generally requires higher maximum grasp forces and thus specifies a decreased acceptable weight for lifting.

Recommended Weight Limit (RWL)

The product of the lifting equation; the load that nearly all healthy workers could perform over a substantial period of time for a specific set of task conditions.

Sagittal line

The line passing through the mid-point between the inner ankle bones and lying in the sagittal plane, as defined by the neutral body position

Short-duration

A term defining lifting tasks that have a work duration of one hour or less, followed by a recovery time equal to 1.2 times the work time {i.e., at least a 1.2 recovery-time to work-time ratio (RT/WT)}.

Significant Control

A term defining a condition requiring "precision placement" of the load at the destination of the lift (e.g.: 1. the worker has to re-grasp the load near the destination of the lift, 2. the worker has to momentarily hold the object at the destination, or 3. the worker has to position or guide the load at the destination).

Single-Task lifting Index (STLI)

A term defined as $(L)/(STRWL)$; identifies individual tasks with potentially excessive physical demands and can prioritize the individual tasks according to the magnitude of their physical stress; values exceeding 1.0, suggest that ergonomic changes may be needed to decrease the overall physical demands of the task.

Single-Task Recommended Weight Limit (STRWL)

A value used in a multi-task assessment; the product of FIRWL and the appropriate FM; reflects the overall demands of that task, assuming it was the only task being performed. May be used to help determine if an individual task represents excessive physical demand; used in Single-Task Lifting Index (see STLI).

Vertical Location (V)

The distance of the hands above the floor measured at the origin and destination of the lift in inches or centimeters; used in the Vertical Multiplier (see VM).

Vertical Multiplier (VM)

A reduction coefficient defined as $(1-(.0075 [V-30]))$, for V measured in inches, and $(1-(.003 [V-$

75])), for V measured in centimeters.

Width (W)

The width of the container in the sagittal plane.

REFERENCES

ASPH/NIOSH, 1986, Proposed National Strategies for the Prevention of Leading Work-Related Diseases and Injuries, Part I, Association of Schools of Public Health under a cooperative agreement with the National Institute for Occupational Safety and Health, Washington D.C.

Ayoub, M.M. and Mital, A. 1989, Manual Materials Handling, (Taylor & Francis, London).

Chaffin, D.B. and Andersson, G.B.J. 1984, Occupational Biomechanics, (John Wiley and Sons, New York)

DOL(BLS), 1982, Back Injuries Associated with Lifting, Bulletin No. 2144. U.S. Department of Labor, Bureau of Labor Statistics.

Eastman Kodak Company, Ergonomics Group, 1986, Ergonomic Design for People at Work, Vol. 2, (Van Nostrand Reinhold, New York)

Gallagher, S., Marras, W.S., and Bobick T.G. 1988, Lifting in stooped and kneeling postures: effects on lifting capacity, metabolic costs, and electromyography of eight trunk muscles, International Journal of Industrial Ergonomics, 3: 65-76.

Gallagher, S. and Unger, R.L. 1990, Lifting in four restricted lifting conditions: psychophysical, physiological and biomechanical effects of lifting in stooped and kneeling postures, Applied Ergonomics, 21, 237-245.

Gallagher, S. 1991, Acceptable weights and physiological costs of performing combined manual handling tasks in restricted postures, Ergonomics, 34(7): 939-952.

Garg, A. 1991, Epidemiological Basis for Manual Lifting Guidelines, NIOSH Project Report (Available from the National Technical Information Service, NTIS number 91-227-348).

Garg, A., Chaffin, D.C., and Herrin, G.D. 1978, Prediction of metabolic rates for manual materials handling jobs, American Industrial Hygiene Association Journal, 39(8):661-764.

National Safety Council, 1990, Accident Facts, National Safety Council, Chicago, IL.

NIOSH 1981, Work Practices Guide for Manual Lifting, NIOSH Technical Report No. 81-122, (U.S. Department of Health and Human Services, National Institute for Occupational Safety and Health, Cincinnati, OH).

Waters, T.R. 1991, Strategies for assessing multi-task manual lifting jobs, Proceedings of the Human Factors Society 35th Annual Meeting -- 1991, San Francisco, California.

Waters, T.R., Putz-Anderson, V., Garg, A. and Fine, L.J. 1993, Revised NIOSH equation for the design and evaluation of manual lifting tasks, Ergonomics, 36(7):749-776.

POINT OF CONTACT FOR THIS DOCUMENT:

To request a copy of this document or for questions concerning this document, please contact the person or office listed below. If requesting a document, please specify the complete name of the document as well as the address to which you would like it mailed. Note that if a name is listed with the address below, you may wish to contact this person via CDC WONDER/PC e-mail.

NATIONAL INSTITUTE FOR OCCUPATIONAL SAFETY AND HEALTH

Table 1

Table 1: Horizontal Multiplier

=====

H	HM	H	HM
---	----	---	----
in		cm	
--		--	
<= 10	1.00	<=25	1.00
11	.91	28	.89
12	.83	30	.83
13	.77	32	.78
14	.71	34	.74
15	.67	36	.69
16	.63	38	.66
17	.59	40	.63
18	.56	42	.60
19	.53	44	.57
20	.50	46	.54
21	.48	48	.52
22	.46	50	.50
23	.44	52	.48
24	.42	54	.46
25	.40	56	.45
>25	.00	58	.43
		60	.42
		63	.40
		>63	.00

=====

Table 2

Table 2: Vertical Multiplier

=====

V	VM	V	VM
---	----	---	----
in		cm	
--		--	
0	.78	0	.78
5	.81	10	.81
10	.85	20	.84
15	.89	30	.87
20	.93	40	.90
25	.96	50	.93

=====

30	1.00	60	.96
35	.96	70	.99
40	.93	80	.99
45	.89	90	.96
50	.85	100	.93
55	.81	110	.90
60	.78	120	.87
65	.74	130	.84
70	.70	140	.81
>70	.00	150	.78
		160	.75
		170	.72
		175	.70
		>175	.00

=====

Table 3

Table 3: Distance Multiplier

D	DM	D	DM
---	----	---	----
in		cm	
--		--	
<=10	1.00	<=25	1.00
15	.94	40	.93
20	.91	55	.90
25	.89	70	.88
30	.88	85	.87
35	.87	100	.87
40	.87	115	.86
45	.86	130	.86
50	.86	145	.85
55	.85	160	.85
60	.85	175	.85
70	.85	>175	.00
>70	.00		

=====

Table 4

Table 4: Asymmetric Multiplier

A	AM
---	----
deg	

0	1.00
15	.95
30	.90
45	.86
60	.81
75	.76
90	.71

105	.66
120	.62
135	.57
>135	.00

Table 5

Table 5: Frequency Multiplier Table (FM)

```

=====
                                Work Duration
-----
Frequency Lifts/min
(F):
-----
    <= 1 Hour    >1 but <=2 Hours    >2 but <=8 Hours
-----
    V<30+    V>=30    V<30    V>=30    V<30    V>=30
-----
    <=0.2    1.00    1.00    .95    .95    .85    .85
    0.5      .97    .97    .92    .92    .81    .81
    1        .94    .94    .88    .88    .75    .75
    2        .91    .91    .84    .84    .65    .65
    3        .88    .88    .79    .79    .55    .55
    4        .84    .84    .72    .72    .45    .45
    5        .80    .80    .60    .60    .35    .35
    6        .75    .75    .50    .50    .27    .27
    7        .70    .70    .42    .42    .22    .22
    8        .60    .60    .35    .35    .18    .18
    9        .52    .52    .30    .30    .00    .15
    10       .45    .45    .26    .26    .00    .13
    11       .41    .41    .00    .23    .00    .00
    12       .37    .37    .00    .21    .00    .00
    13       .00    .34    .00    .00    .00    .00
    14       .00    .31    .00    .00    .00    .00
    15       .00    .28    .00    .00    .00    .00
    >15      .00    .00    .00    .00    .00    .00
=====

```

+ Values of V are in inches
: For lifting less frequently than once per 5 minutes, set
F = 0.2 lifts/minute.

Table 6

Table 6: Hand-to-Container Coupling Classification

```

=====
                                GOOD                                FAIR                                POOR
-----
1. For containers of optimal design such as some boxes crates, etc., a "Good" hand-to object coupling would be defined as handles or hand-hold cut-outs of optimal design {see
1. For containers of optimal design, a "Fair" hand-to-object coupling would be defined as handles or hand-hold cut-outs of less than optimal design {see notes 1 to 4 below}.
1. Containers of less than optimal design or loose parts or irregular objects that are bulky, hard to handle, or have sharp edges {see notes below}.
=====

```

notes 1 to 3 below}

- | | | |
|--|---|--|
| 2. For loose parts or irregular objects, which are not usually containerized, such as castings, stock, and supply materials, a "Good" hand-to-object coupling would be defined as a comfortable grip in which the hand can be easily wrapped around the object {see note 6 below}. | 2. For containers of optimal design with no handles or hand-hold cut-outs or for loose parts or irregular objects, a "Fair" hand-to-object coupling is defined as a grip in which the hand can be flexed about 90 degrees {see note 4 below}. | 2. Lifting non-rigid bags (i.e., bags that sag in the middle). |
|--|---|--|

NOTES:

1. An optimal handle design has 0.75-1.5 inches (1.9 to 3.8cm) diameter, \geq 4.5 inches (11.5 cm) length, 2 inches (5 cm) clearance, cylindrical shape, and a smooth, non-slip surface.
2. An optimal hand-hold cut-out has the following approximate characteristics: \geq 1.5 inch (3.8 cm) height, 4.5 (11.5 cm) length, semi-oval shape, \geq 2 inches (5 cm) clearance, smooth non-slip surface, and \geq 0.25 inches (0.60 cm) container thickness (e.g., double thickness cardboard).
3. An optimal container design has \leq 16 inches (40 cm) frontal length, \leq 12 inches (30 cm) height, and a smooth non-slip surface.
4. A worker should be capable of clamping the fingers nearly 90 degrees under the container, such as required when lifting a cardboard box from the floor.
5. A container is considered less than optimal if it has a frontal length $>$ 16 inches (40 cm), height $>$ 12 inches (30 cm), rough or slippery surfaces, sharp edges, asymmetric center of mass, unstable contents, or requires the use of gloves. A loose object is considered bulky if the load cannot easily be balanced between the hand-grasps.
6. A worker should be able to comfortably wrap the hand around the object without causing excessive wrist deviations or awkward postures, and the grip should not require excessive force.

=====

Table 7

Table 7: Coupling Multiplier

=====

Coupling Type	Coupling Multiplier	
	V < 30 inches (75 cm)	V >= 30 inches (75 cm)
Good	1.00	1.00
Fair	0.95	1.00
Poor	0.90	0.90

Table 8

Table 8: General Design/Redesign Suggestions

If HM is less than 1.0	Bring the load closer to the worker by removing any horizontal barriers or reducing the size of the object. Lifts near the floor should be avoided; if unavoidable, the object should fit easily between the legs.
If VM is less than 1.0	Raise/lower the origin/destination of the lift. Avoid lifting near the floor or above the shoulders.
If DM is less than 1.0	Reduce the vertical distance between the origin and the destination of the lift.
If AM is less than 1.0	Move the origin and destination of the lift closer together to reduce the angle of twist, or move the origin and destination further apart to force the worker to turn the feet and step, rather than twist the body.
If FM is less than 1.0	Reduce the lifting frequency rate, reduce the lifting duration, or provide longer recovery periods (i.e., light work period).
If CM is less than 1.0	Improve the hand-to-object coupling by providing optimal containers with handles or handhold cutouts, or improve the handholds for irregular objects.
If the RWL at the destination is less than at the origin	Eliminate the need for significant control of the object at the destination by redesigning the job or modifying the container/object characteristics. (See requirements for significant control, p.36, 43.)

Figure 1

Graphic Representation of Hand Location

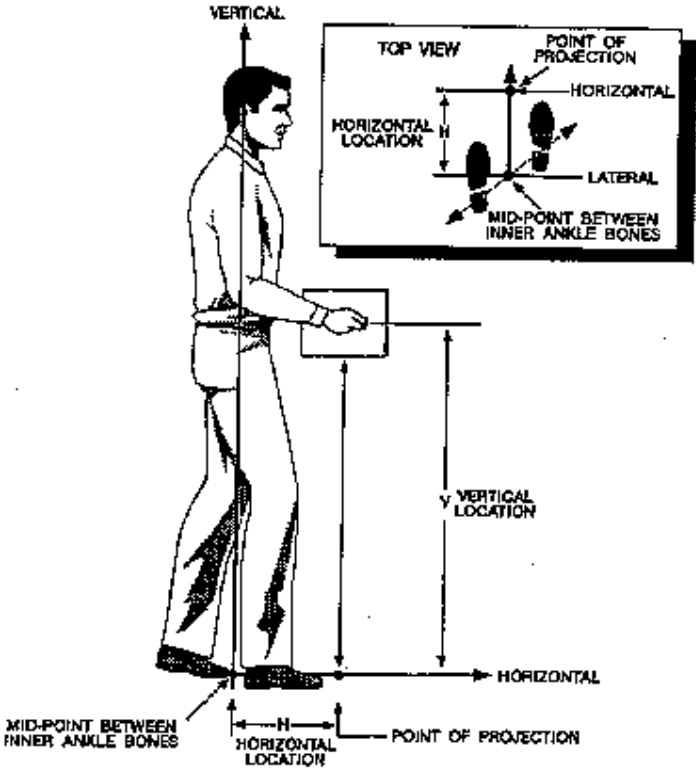

Figure 1 Graphic Representation of Hand Location

Figure 2

Graphic Representation of Angle of Asymmetry

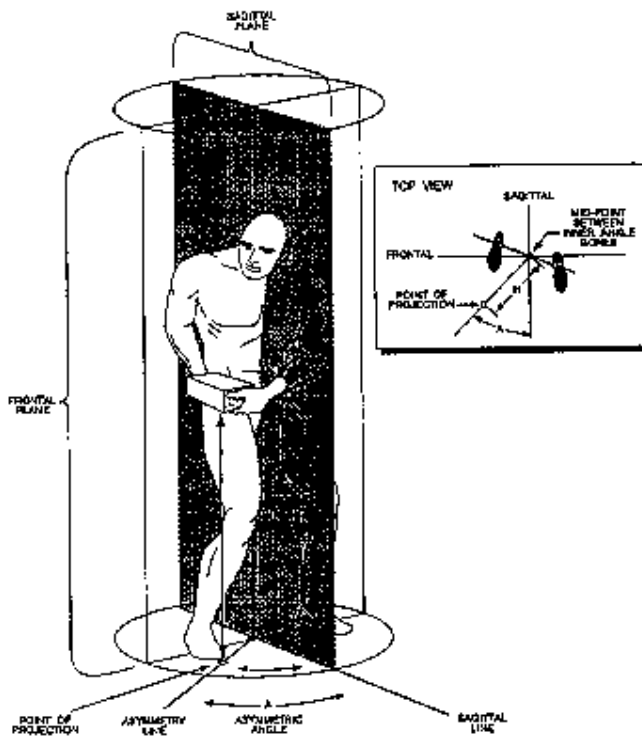

Figure 2 Graphic Representation of Angle of Asymmetry (A)

Figure 3

Single Task Job Analysis Worksheet

JOB ANALYSIS WORKSHEET														
DEPARTMENT _____				JOB DESCRIPTION _____										
JOB TITLE _____				_____										
ANALYST'S NAME _____				_____										
DATE _____				_____										
STEP 1. Measure and record task variables														
Object Weight (lbs)	Hand Location (ft)				Vertical Distance (ft)	Asymmetric Angle (degrees)		Frequency Rate (times/min)	Duration (secs)	Container Coupling				
	Origin		Dest.			Origin	Destination			Origin	Destination			
	H	V	H	V		A	A			C	C			
L														
STEP 2. Determine the multipliers and compute the RWL's RWL = LC · HM · VM · DM · AM · FM · CM														
ORIGIN	RWL =	<input type="text" value="51"/>	·	<input type="text"/>	·	<input type="text"/>	·	<input type="text"/>	·	<input type="text"/>	·	<input type="text"/>	=	<input type="text" value="Lbs"/>
DESTINATION	RWL =	<input type="text" value="51"/>	·	<input type="text"/>	·	<input type="text"/>	·	<input type="text"/>	·	<input type="text"/>	·	<input type="text"/>	=	<input type="text" value="Lbs"/>
Determine multipliers from Tables 4-9														
STEP 3. Compute the LIFTING INDEX														
ORIGIN	LIFTING INDEX =	$\frac{\text{OBJECT WEIGHT (L)}}{\text{RWL}}$		=	<input type="text"/>	=	<input type="text"/>							
DESTINATION	LIFTING INDEX =	$\frac{\text{OBJECT WEIGHT (L)}}{\text{RWL}}$		=	<input type="text"/>	=	<input type="text"/>							

Figure 3: Single Task Job Analysis Worksheet

Figure 4

Multi-Task Job Analysis Worksheet

MULTI-TASK JOB ANALYSIS WORKSHEET												
DEPARTMENT _____				JOB DESCRIPTION _____								
JOB TITLE _____				_____								
ANALYST'S NAME _____				_____								
DATE _____				_____								
STEP 1. Measure and Record Task Variable Data												
Task No.	Object Weight (lbs)		Hand Location (in)				Vertical Distance (in)	Asymmetry Angle (deg)		Frequency Rate lifts/min	Duration min	Coupling
	L (Avg.)	L (Max.)	Origin		Dest.			Origin	Dest.			
	H	V	H	V	D	A	A	F	C			
STEP 2. Compute multipliers and FIRWL, STRWL, FILI, and STLI for Each Task												
Task No.	LC	HM	VM	DM	AM	CM	FIRWL x FM	STRWL	FIL = L/FIRWL	STLI = L/STRWL	New Task No.	F
51												
51												
51												
51												
51												
STEP 3. Compute the Composite Lifting Index for the Job (After renumbering tasks)												
CLI =	STLI ₁		+ Δ FILI ₁		+ Δ FILI ₂		+ Δ FILI ₃		+ Δ FILI ₄		+ Δ FILI ₅	
	FILI ₁ (1/FM _{1,1} - 1/FM _{1,2})		FILI ₂ (1/FM _{2,1} - 1/FM _{2,2})		FILI ₃ (1/FM _{3,1} - 1/FM _{3,2})		FILI ₄ (1/FM _{4,1} - 1/FM _{4,2})		FILI ₅ (1/FM _{5,1} - 1/FM _{5,2})			
CLI =												

Figure 4: MULTI-TASK JOB ANALYSIS WORKSHEET

Figure 5

Loading Punch Press Stock, Example 1

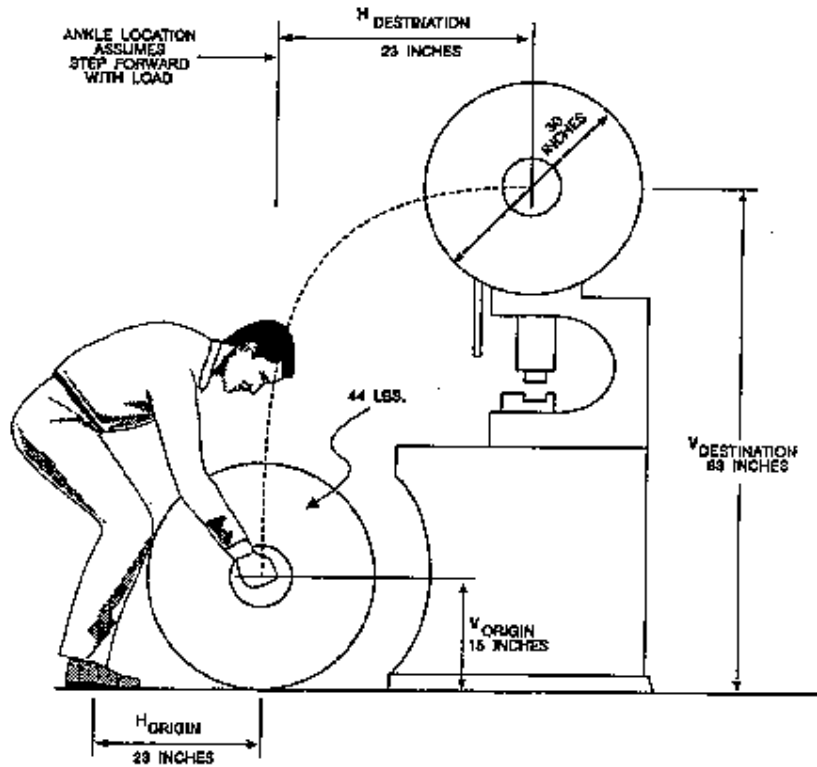

Figure 5 Loading Punch Press Stock, Example 1

Figure 6

Job Analysis Worksheet, Example 1

JOB ANALYSIS WORKSHEET											
DEPARTMENT		Manufacturing					JOB DESCRIPTION				
JOB TITLE		Punch Press Operator					Loading supply stock onto				
ANALYST'S NAME							punch press machine				
DATE							Example 1				
STEP 1. Measure and record task variables											
Object Weight (lbs)		Hand Location (in)				Vertical Distance (in)	Asymmetric Angle (degrees)		Frequency Rate (lifts/min)	Duration (HRS)	Object Coupling
		Origin		Dest.			Origin	Destination			
L (AVG.)	L (Max)	H	V	H	V	D	A	A	F	C	
44	44	23	15	23	63	48	0	0	<.2	<1	Fair
STEP 2. Determine the multipliers and compute the RWL's											
$RWL = LC \times HM \times VM \times DM \times AM \times FM \times CM$											
ORIGIN		$RWL = 51 \times .44 \times .89 \times .86 \times 1.0 \times 1.0 \times .95 = 16.3 \text{ Lbs}$									
DESTINATION		$RWL = 51 \times .44 \times .75 \times .86 \times 1.0 \times 1.0 \times 1.0 = 14.5 \text{ Lbs}$									
STEP 3. Compute the LIFTING INDEX											
ORIGIN		LIFTING INDEX = $\frac{\text{OBJECT WEIGHT (L)}}{\text{RWL}} = \frac{44}{16.3} = 2.7$									
DESTINATION		LIFTING INDEX = $\frac{\text{OBJECT WEIGHT (L)}}{\text{RWL}} = \frac{44}{14.5} = 3.0$									

Figure 6: Example 1, Job Analysis Worksheet

Figure 7

Modified Job Analysis Worksheet, Example 1

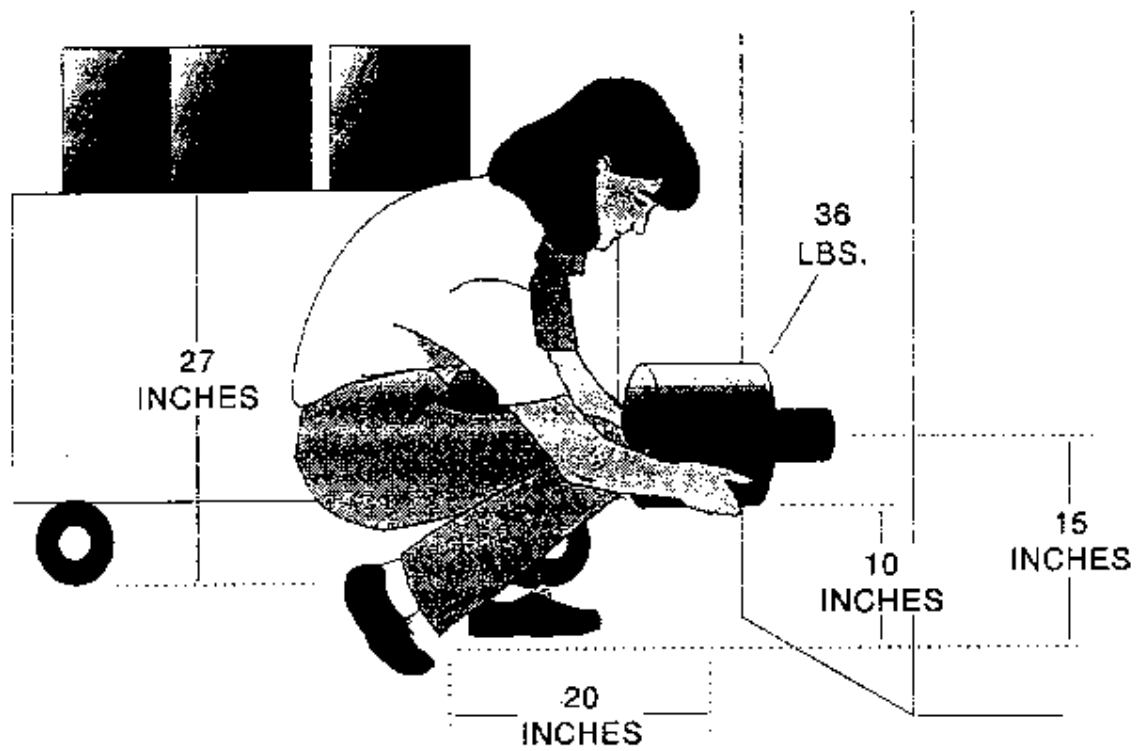

Figure 8 Loading Supply Rolls, Example 2

Figure 9

Job Analysis Worksheet, Example 2

JOB ANALYSIS WORKSHEET												
DEPARTMENT		Shipping						JOB DESCRIPTION				
JOB TITLE		Packager						Loading paper supply rolls				
ANALYST'S NAME								Modified Example 2				
DATE												
STEP 1. Measure and record task variables												
Object Weight (lbs)		Hand Location (in)				Vertical Distance (in)	Asymmetric Angle (degrees)		Frequency Rate (lifts/min)	Duration (HRS)	Object Coupling	
		Origin		Dest.			Origin	Destination				
L (AVG.)	L (Max.)	H	V	H	V	D	A	A	F	C		
35	35	15	27	15	30	3	0	0	<.2	<.1	Poor	
STEP 2. Determine the multipliers and compute the RWL's												
RWL = LC × HM × VM × DM × AM × FM × CM												
ORIGIN		RWL = .51 × .67 × .98 × 1.0 × 1.0 × 1.0 × .90 =									30.1 Lbs	
DESTINATION		RWL = .51 × .67 × 1.0 × 1.0 × 1.0 × 1.0 × .90 =									30.8 Lbs	
STEP 3. Compute the LIFTING INDEX												
ORIGIN		LIFTING INDEX =		$\frac{\text{OBJECT WEIGHT (L)}}{\text{RWL}} = \frac{35}{30.1} =$						1.2		
DESTINATION		LIFTING INDEX =		$\frac{\text{OBJECT WEIGHT (L)}}{\text{RWL}} = \frac{35}{30.8} =$						1.1		

Figure 10: Example 2, Modified Job Analysis Worksheet

Figure 11

Loading Bags into Hopper, Example 3

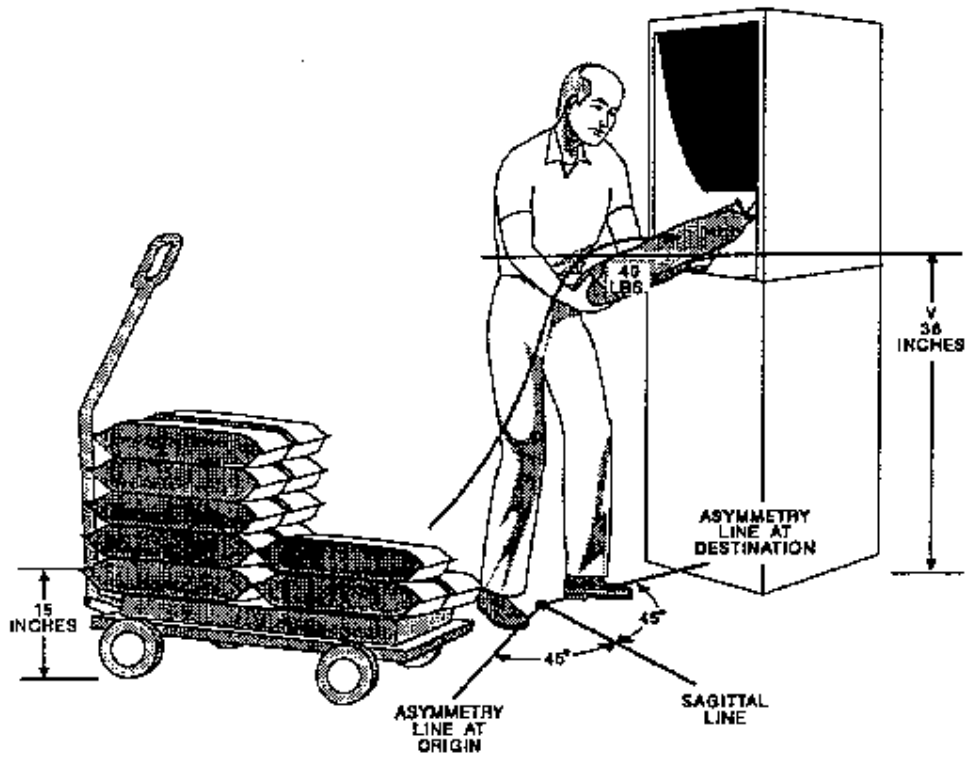

Figure 11 Loading Bags Into Hopper, Example 3

Figure 12

Job Analysis Worksheet, Example 3

JOB ANALYSIS WORKSHEET

DEPARTMENT	<u>Manufacturing</u>	JOB DESCRIPTION
JOB TITLE	<u>Batch Processor</u>	<u>Dumping bags into mixing hopper</u>
ANALYST'S NAME	_____	<u>Example 3</u>
DATE	_____	_____

STEP 1. Measure and record task variables

Object Weight (lbs)		Hand Location (In)				Vertical Distance (In)	Asymmetric Angle (degrees)		Frequency Rate (lifts/min)	Duration (HRS)	Object Coupling
		Origin		Dest.			Origin	Destination			
L (AVG.)	L (Max.)	H	V	H	V	D	A	A	F		C
40	40	18	18	10	36	21	45	45	<.2	<1	Fair

STEP 2. Determine the multipliers and compute the RWL's

RWL = LC × HM × VM × DM × AM × FM × CM

ORIGIN RWL = × × × × × × =

DESTINATION RWL = × × × × × × =

STEP 3. Compute the LIFTING INDEX

ORIGIN LIFTING INDEX = $\frac{\text{OBJECT WEIGHT (L)}}{\text{RWL}} = \frac{40}{18.9} = \text{2.1}$

DESTINATION LIFTING INDEX = $\frac{\text{OBJECT WEIGHT (L)}}{\text{RWL}} = \frac{\quad}{\quad} = \text{}$

Figure 12: Example 3, Job Analysis Worksheet

Figure 13

Package Inspection, Example 4

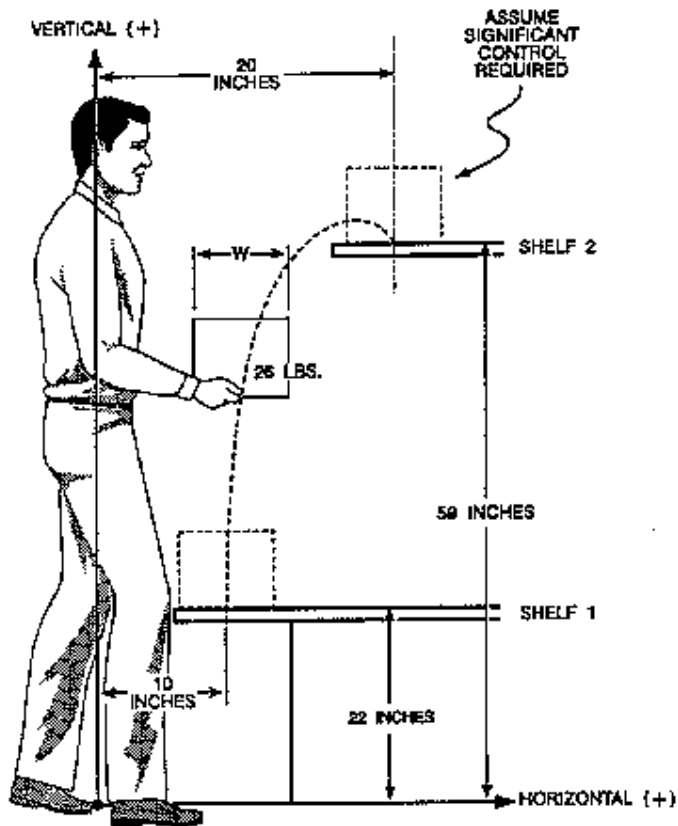

Figure 13 Package Inspection, Example 4

Figure 14

Job Analysis Worksheet, Example 4

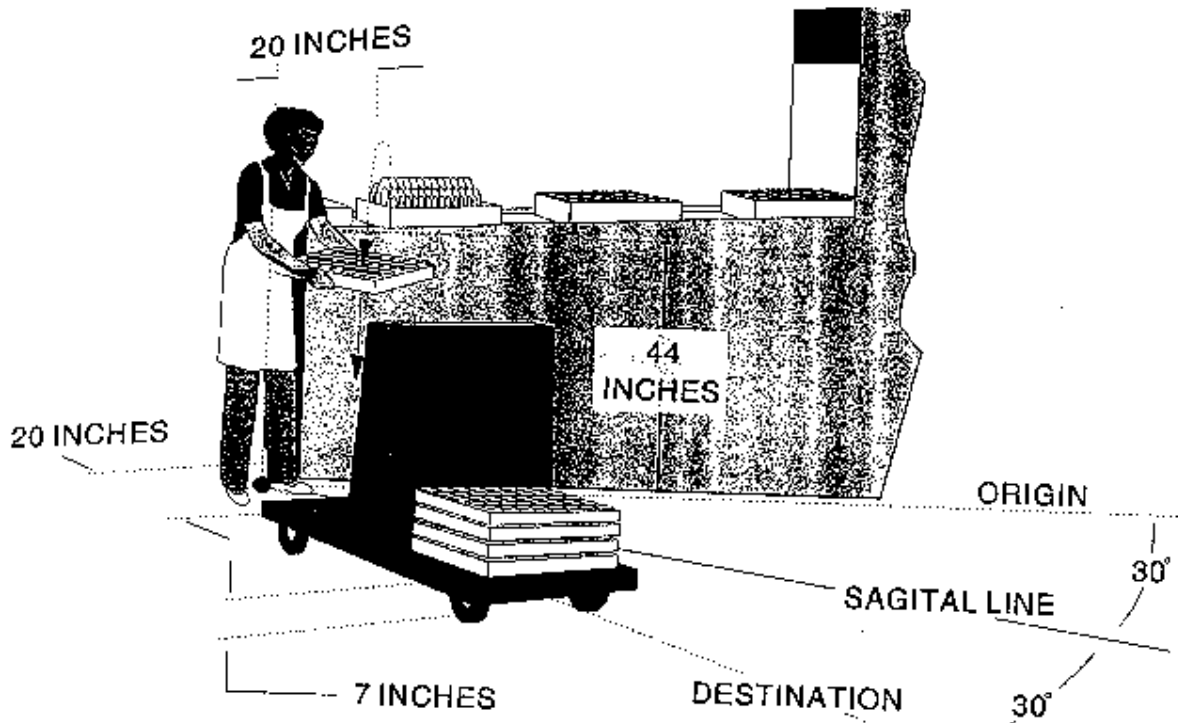

Figure 15 Dish-Washing Machine Unloading, Example 5

Figure 16

Job Analysis Worksheet, Example 5

JOB ANALYSIS WORKSHEET

DEPARTMENT	Food Service	JOB DESCRIPTION
JOB TITLE	Cafeteria Worker	Unloading a dish-washing machine
ANALYST'S NAME		Example 5
DATE		

STEP 1. Measure and record task variables

Object Weight (lbs)		Hand Location (in)				Vertical Distance (in)	Asymmetric Angle (degrees)		Frequency Rate (lifts/min)	Duration (HRS)	Object Coupling
		Origin		Dest.			Origin	Destination			
L (AVG.)	L (Max.)	H	V	H	V	D	A	A	F		C
20	20	20	44	20	7	37	30	30	5	< 1	Good

STEP 2. Determine the multipliers and compute the RWL's

RWL = LC × HM × VM × DM × AM × FM × CM

ORIGIN RWL = 51 × .50 × .90 × .87 × .90 × .80 × 1.0 = 14.4 Lbs

DESTINATION RWL = 51 × .50 × .83 × .87 × .90 × .80 × 1.0 = 13.3 Lbs

STEP 3. Compute the LIFTING INDEX

ORIGIN LIFTING INDEX = $\frac{\text{OBJECT WEIGHT (L)}}{\text{RWL}} = \frac{20}{14.4} = 1.4$

DESTINATION LIFTING INDEX = $\frac{\text{OBJECT WEIGHT (L)}}{\text{RWL}} = \frac{20}{13.3} = 1.5$

Figure 16: Example 5, Job Analysis Worksheet

Figure 17

Modified Job Analysis Worksheet, Example 5

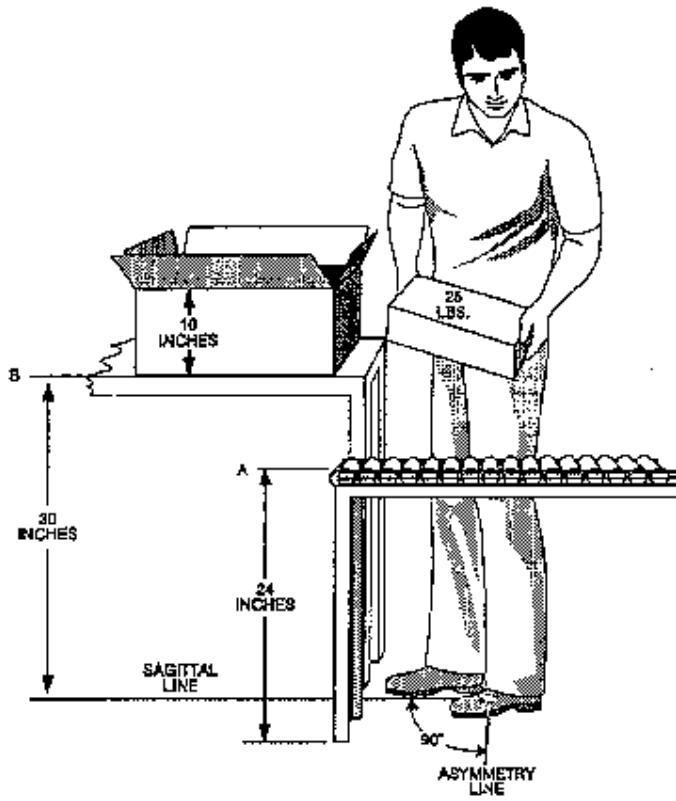

Figure 18 Packaging I, Example 6

Figure 19

Job Analysis Worksheet, Example 6

JOB ANALYSIS WORKSHEET

DEPARTMENT	Distribution	JOB DESCRIPTION	Packing products for distribution
JOB TITLE	Line Packer	ANALYST'S NAME	
DATE			Example 6, Product Packaging I

STEP 1. Measure and record task variables

Object Weight (lbs)		Hand Location (in)				Vertical Distance (in)	Asymmetric Angle (degrees)		Frequency Rate (lifts/min)	Duration (HRS)	Object Coupling
		Origin		Dest.			Origin	Destination			
L (AVG.)	L (Max.)	H	V	H	V	D	A	A	F	C	
25	25	14	24	16	40	16	90	0	1	8	Fair

STEP 2. Determine the multipliers and compute the RWL's

RWL = LC × HM × VM × DM × AM × FM × CM

ORIGIN RWL = × × × × × × =

DESTINATION RWL = × × × × × × =

STEP 3. Compute the LIFTING INDEX

ORIGIN LIFTING INDEX = $\frac{\text{OBJECT WEIGHT (L)}}{\text{RWL}} = \frac{25}{16.4} = \text{1.5}$

DESTINATION LIFTING INDEX = $\frac{\text{OBJECT WEIGHT (L)}}{\text{RWL}} = \frac{\text{---}}{\text{---}} = \text{---}$

Figure 19: Example 6, Job Analysis Worksheet

Figure 20

Modified Job Analysis Worksheet, Example 6

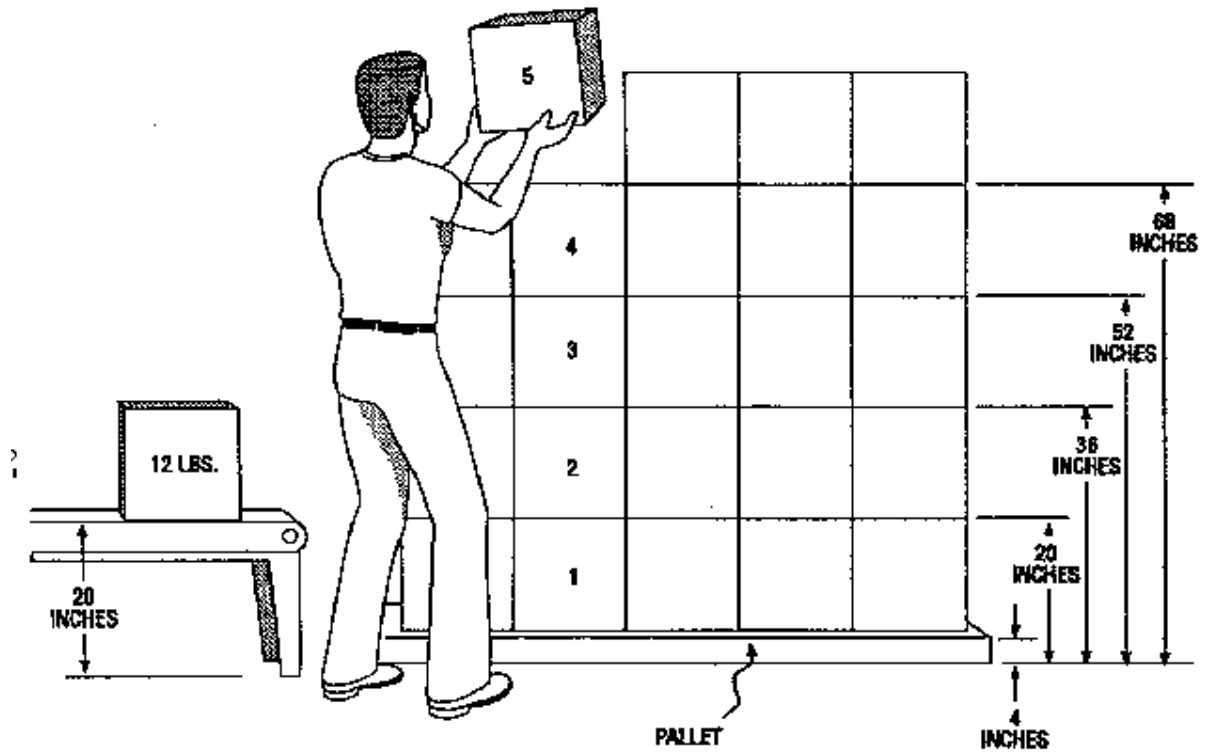

Figure 21 Depalletizing Operation, Example 7

Figure 22

Job Analysis Worksheet, Example 7

MULTI-TASK JOB ANALYSIS WORKSHEET													
DEPARTMENT		Receiving					JOB DESCRIPTION						
JOB TITLE		Warehouseman					Unloading boxes onto a						
ANALYST'S NAME							conveyor						
DATE							Example 7						
STEP 1. Measure and Record Task Variable Data													
Task No.	Object Weight (lbs)		Hand Location (in)				Vertical Distance (in)	Asymmetry Angle (degs)		Frequency Rate (lifts/min)	Duration (Hrs)	Coupling	C
	L (Avg.)	L (Max.)	H	V	H	V		Origin	Dest.				
1	12	12	18	4	16	20	16	0	0	2.4	1	Fair	
2	12	12	16	20	16	20	0	0	0	2.4	1	Fair	
3	12	12	16	36	16	20	16	0	0	2.4	1	Fair	
4	12	12	16	52	16	20	32	0	0	2.4	1	Fair	
5	12	12	16	68	16	20	48	0	0	2.4	1	Fair	
STEP 2. Compute multipliers and FIRWL, STRWL, FILI, and STLI for Each Task													
Task No.	LC x	HM x	VM x	DM x	AM x	CM	FIRWL x	FM	STRWL	FILI = L/FIRWL	STLI = L/STRWL	Now Task No.	F
1	51	.58	.81	.93	1.0	.95	20.4	.90	18.4	.6	.7	2	2.4
2	51	.83	.93	1.0	1.0	.95	28.4	.90	25.6	.4	.5	4	2.4
3	51	.83	.96	.93	1.0	1.0	28.7	.90	25.8	.4	.5	5	2.4
4	51	.63	.84	.88	1.0	1.0	23.8	.90	21.4	.5	.6	3	2.4
5	51	.63	.72	.86	1.0	1.0	19.9	.90	17.9	.6	.7	1	2.4
STEP 3. Compute the Composite Lifting Index for the Job (After renumbering tasks)													
CLI = STLI ₁ + Δ FILI ₂ + Δ FILI ₃ + Δ FILI ₄ + Δ FILI ₅													
$= \text{STLI}_1 + \frac{\text{FILI}_2(1/\text{FM}_{1,2} - 1/\text{FM}_1)}{1} + \frac{\text{FILI}_3(1/\text{FM}_{1,3} - 1/\text{FM}_{1,2})}{1} + \frac{\text{FILI}_4(1/\text{FM}_{1,4} - 1/\text{FM}_{1,3})}{1} + \frac{\text{FILI}_5(1/\text{FM}_{1,5} - 1/\text{FM}_{1,4})}{1}$													
$= .7 + .07 + .12 + .26 + .26 = 1.4$													

Figure 22: Example 7, JOB ANALYSIS WORKSHEET

Figure 23

Handling Cans of Liquid, Example 8

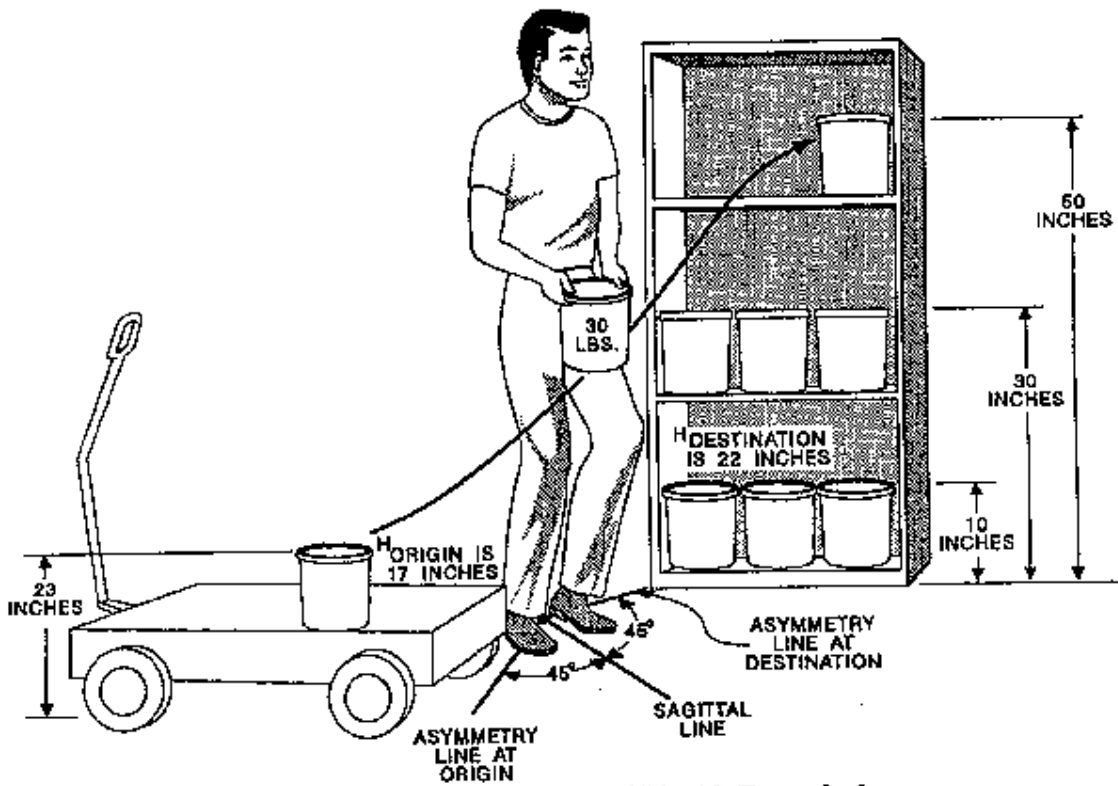

Figure 23 Handling Cans of Liquid, Example 8

Figure 24

Job Analysis Worksheet, Example 8

MULTI-TASK JOB ANALYSIS WORKSHEET														
DEPARTMENT		Paint Shop					JOB DESCRIPTION							
JOB TITLE		Stock Clerk					Lifting cans of liquid from							
ANALYST'S NAME							from cart to shelves							
DATE							Example 8							
STEP 1. Measure and Record Task Variable Data														
Task No.	Object Weight (lbs)		Hand Location (in)				Vertical Distance (in)	Asymmetry Angle (deg)		Frequency Rate lifts/min	Duration Hrs	Coupling		
	L (Avg)	L (Max)	H	V	H	V		Origin	Dest.					
							D	A	A	F	G			
1	30	30	17	23	22	10	13	45	45	3	< 1	Poor		
2	30	30	17	23	22	30	7	45	45	3	< 1	Poor		
3	30	30	17	23	22	50	27	45	45	3	< 1	Poor		
STEP 2. Compute multipliers and FIRWL, STRWL, FILI, and STLI for Each Task														
Task No.	LC x	HM x	VM x	DM x	AM x	CM	FIRWL x	FM	STRWL	FIL I = L/FIRWL	STLI = L/STRWL	New Task No.	F	
1	51	.59	.95	.96	.86	.90	21.2	.90	19.1	1.4	1.6	2	2.4	
2	51	.59	.95	1.0	.86	.90	22.1	.90	19.9	1.4	1.5	3	2.4	
3a	51	.59	.95	.89	.86	.90	19.7	.90	17.7	1.5	1.7	2	2.4	
3b	51	.46	.85	.89	.86	.90	13.7	.90	12.4	2.2	2.4	1	2.4	
	51													
STEP 3. Compute the Composite Lifting Index for the Job (After renumbering tasks)														
CLI = STLI ₁ + Δ FILI ₂ + Δ FILI ₃ + Δ FILI ₄ + Δ FILI ₅														
$= \text{STLI}_1 + \frac{\text{FILI}_2(1/\text{FM}_{1,2} - 1/\text{FM}_1)}{1/\text{FM}_1} + \frac{\text{FILI}_3(1/\text{FM}_{1,3} - 1/\text{FM}_1)}{1/\text{FM}_1} + \frac{\text{FILI}_4(1/\text{FM}_{1,4} - 1/\text{FM}_1)}{1/\text{FM}_1} + \frac{\text{FILI}_5(1/\text{FM}_{1,5} - 1/\text{FM}_1)}{1/\text{FM}_1}$														
$\text{CLI} = 2.4 + \frac{1.4(1/.8 - 1/.9)}{1/.9} + \frac{1.4(1/.7 - 1/.8)}{1/.8} + \frac{1.5(1/.6 - 1/.7)}{1/.7} + \frac{1.7(1/.5 - 1/.6)}{1/.6}$														
CLI = 2.4 + .19 + .25 + .25 + .25 = 2.9														

Figure 24: Example 8, JOB ANALYSIS WORKSHEET

Figure 25

Product Packaging II, Example 9

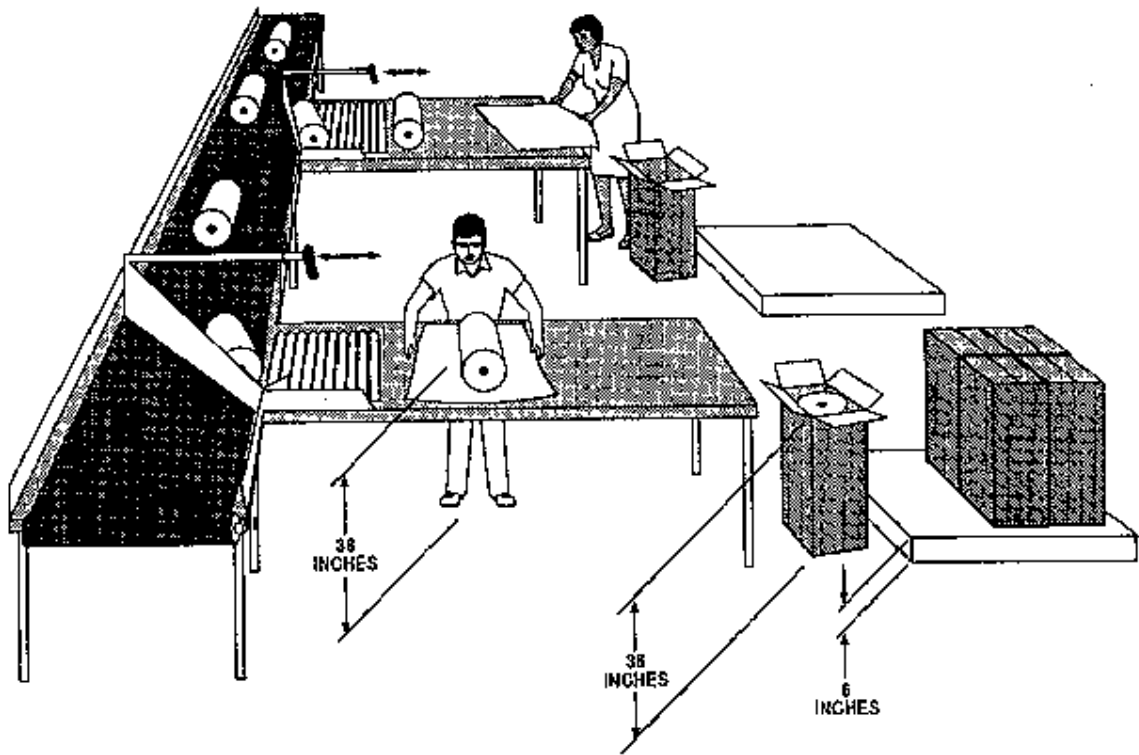

Figure 25 Product Packaging II, Example 9

Figure 26

Job Analysis Worksheet, Example 9

MULTI-TASK JOB ANALYSIS WORKSHEET													
DEPARTMENT	Shipping					JOB DESCRIPTION	Wrapping and boxing products and lifting them to a pallet Example 9, Product Packaging II						
JOB TITLE	Packager												
ANALYST'S NAME													
DATE													
STEP 1. Measure and Record Task Variable Data													
Task No.	Object Weight (lbs)		Hand Location (in)				Vertical Distance (in)	Asymmetry Angle (deg)		Frequency Rate lifts/min	Duration Hrs	Coupling C	
	L (Avg)	L (Max)	Origin		Dest			Origin	Dest				
			H	V	H	V		A	A				
1	25	25	21	38	10	36	2	0	0	1	8	Poor	
2	25	25	10	0	10	6	6	0	0	1	8	Fair	
STEP 2. Compute multipliers and FIRWL, STRWL, FILI, and STLI for Each Task													
Task No.	LC	HM	VM	DM	AM	CM	FIRWL	FM	STRWL	FIL = L/FIRWL	STLI = L/STRWL	New Task No.	F
1a	51	.48	.94	1.0	1.0	.90	20.7	.75	15.5	1.2	1.6	1	1
1b	51	1.0	.96	1.0	1.0	.90	44.1	.75	33.1	.6	.8	1	1
2	51	1.0	.78	1.0	1.0	.95	37.8	.75	28.4	.7	.9	2	1
	51												
	51												
STEP 3. Compute the Composite Lifting Index for the Job (After renumbering tasks)													
CLI =	$STLI_1 + \Delta FILI_1 + \Delta FILI_2 + \Delta FILI_3 + \Delta FILI_4 + \Delta FILI_5$												
	$FILI_1(1/FM_{1,1} - 1/FM_{1,2}) + FILI_2(1/FM_{2,1} - 1/FM_{2,2}) + FILI_3(1/FM_{3,1} - 1/FM_{3,2}) + FILI_4(1/FM_{4,1} - 1/FM_{4,2}) + FILI_5(1/FM_{5,1} - 1/FM_{5,2})$												
	$.7(1/.65 - 1/.75)$												
CLI =	1.6	.14										1.7	

Figure 26: Example 9, JOB ANALYSIS WORKSHEET

Figure 27

Warehouse Order Filling, Example 10

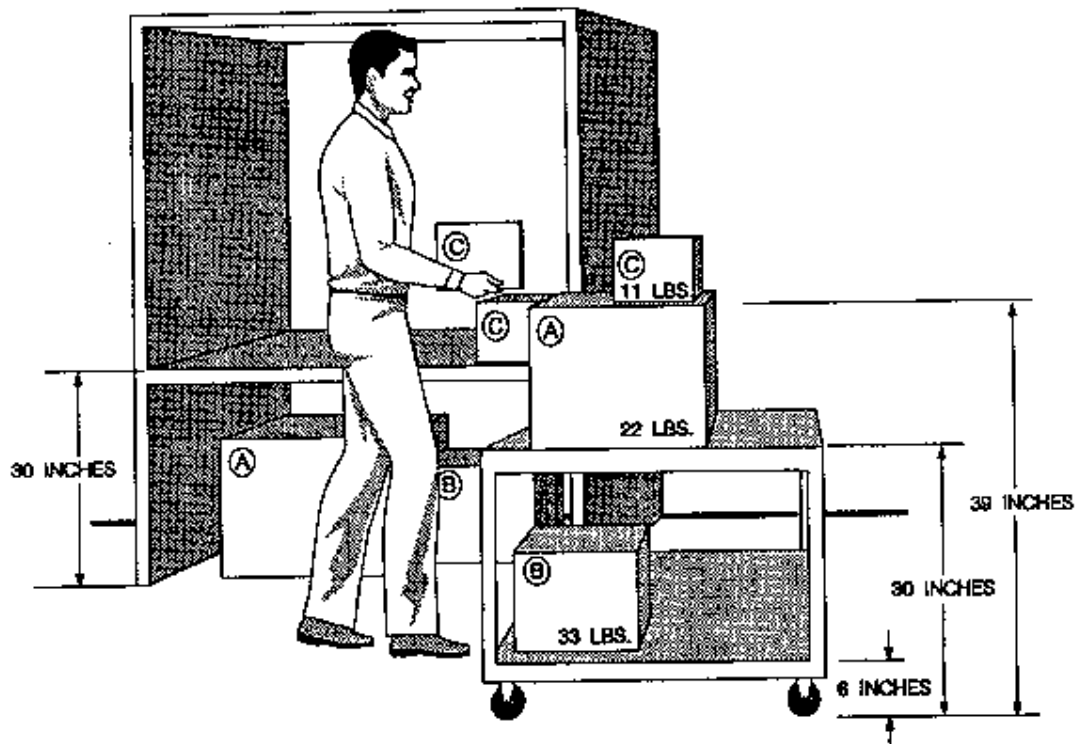

Figure 27 Warehouse Order Filling, Example 10

Figure 28

Job Analysis Worksheet, Example 10

MULTI-TASK JOB ANALYSIS WORKSHEET														
DEPARTMENT		Warehouse					JOB DESCRIPTION							
JOB TITLE		Shipping Clerk					Selecting an order for shipment							
ANALYST'S NAME							Warehouse order filling							
DATE							Example 10							
STEP 1. Measure and Record Task Variable Data														
Task No.	Object Weight (lbs)		Hand Location (in)				Vertical Distance (in)	Asymmetry Angle (deg)		Frequency Rate (lits/min)	Duration (Hrs)	Coupling		
	L (Avg.)	L (Max.)	H	V	H	V		Origin	Dest.				A	A
	D	A	A	F	C									
1 (A)	22	33	18	0	16	30	30	0	0	1	8	Fair		
2 (B)	33	44	12	0	12	6	6	0	0	2	8	Fair		
3 (C)	11	22	8	30	8	39	9	0	0	5	8	Fair		
STEP 2. Compute multipliers and FIRWL, STRWL, FILI, and STLI for Each Task														
Task No.	LC x	HM x	VM x	DM x	AM x	CM	FIRWL x	FM	STRWL	FIL = L/FIRWL	STLI = L/STRWL	New Task No.	F	
1	51	.63	.78	.88	1.0	.95	21.0	.75	15.8	1.6	1.4	2	1	
2	51	.83	.78	1.0	1.0	.95	31.4	.68	20.4	1.4	1.6	1	2	
3	51	1.0	1.0	1.0	1.0	1.0	51.0	.35	17.8	.4	.6	3	5	
	51													
	51													
STEP 3. Compute the Composite Lifting Index for the Job (After renumbering tasks)														
$CLI = STLI_1 + \Delta FILI_2 + \Delta FILI_3 + \Delta FILI_4 + \Delta FILI_5$														
$CLI = 1.6 + .45 + 1.5 + \dots + \dots = 3.6$														
$CLI = 1.6 + .45 + 1.5 + \dots + \dots = 3.6$														

Figure 28: Example 10, JOB ANALYSIS WORKSHEET

Figure C1

Chart 1

Decision Tree for Coupling Quality

Object Lifted

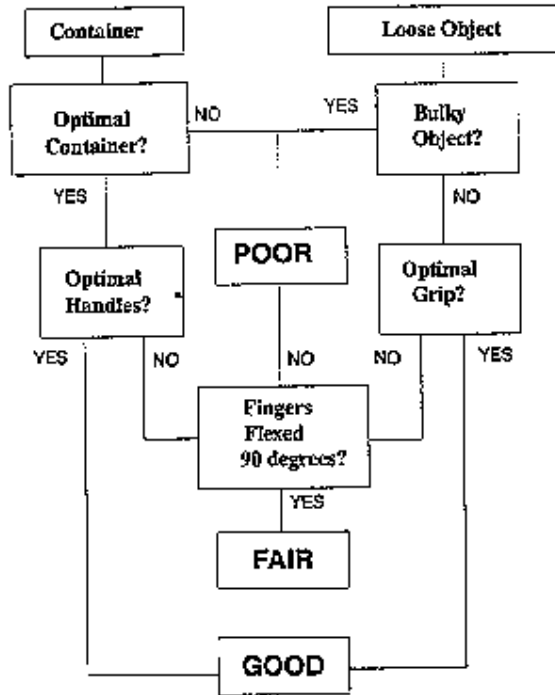

Figure C2

Chart 2

$$CLI = STLI_1 + \sum \Delta LI$$

$$\sum \Delta LI = (FIL_2 \times \left(\frac{1}{FM_{1,2}} - \frac{1}{FM_1} \right))$$

$$+(FIL_3 \times \left(\frac{1}{FM_{1,2,3}} - \frac{1}{FM_{1,2}} \right))$$

$$+(FIL_4 \times \left(\frac{1}{FM_{1,2,3,4}} - \frac{1}{FM_{1,2,3}} \right))$$

⋮

$$+(FIL_n \times \left(\frac{1}{FM_{1,2,3,4,\dots,n}} - \frac{1}{FM_{1,2,3,\dots,(n-1)}} \right))$$

Figure C3

Chart 3

Task Number	1	2	3
Load Weight (L)	30	20	10
Task Frequency (F)	1	2	4
FIRWL	20	20	15
FM	.94	.91	.84
STRWL	18.8	18.2	12.6
FILI	1.5	1.0	.67
STLI	1.6	1.1	.8
New Task Number	1	2	3

Applications Manual For the Revised NIOSH Lifting Equation

Thomas R. Waters, Ph.D., Vern Putz-Anderson, Ph.D., Arun Garg, Ph.D. Centers for Disease Control & Prevention

Publication date: 01/01/1994
