

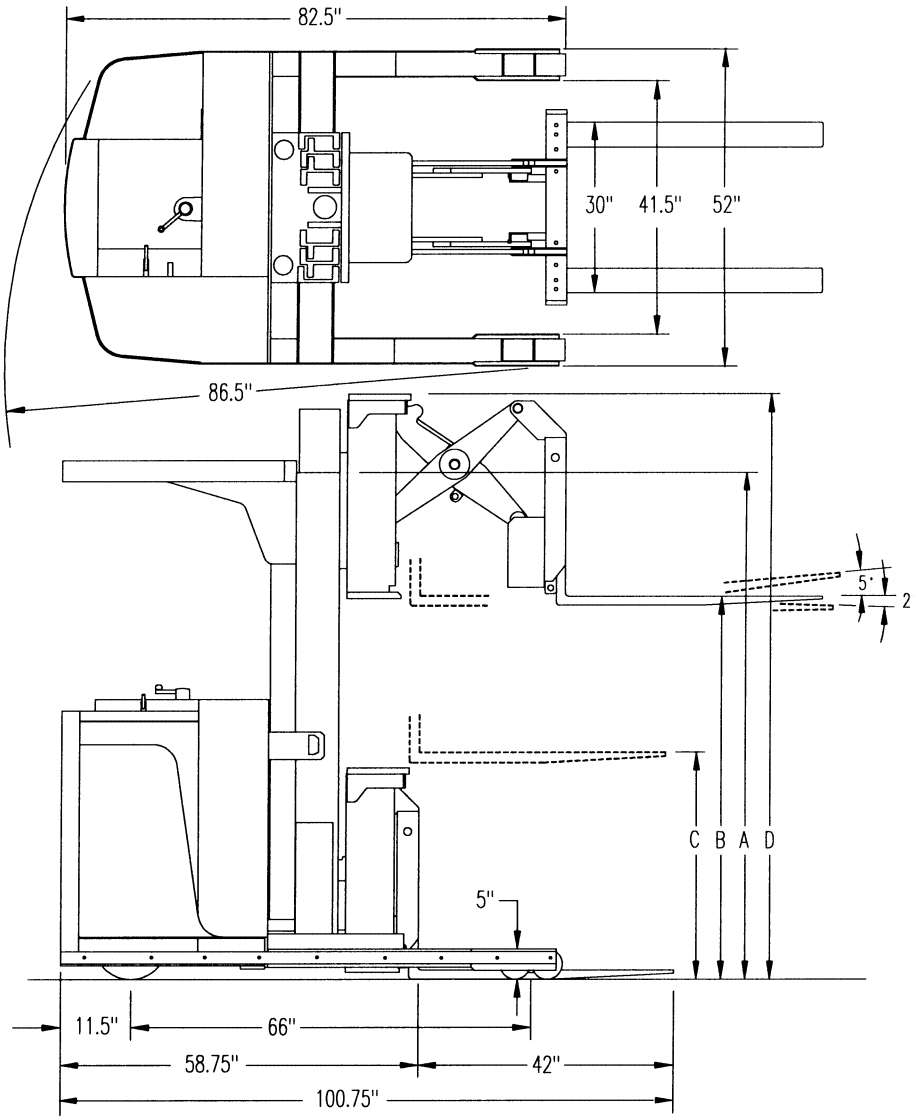

# GREGORY Model RR-EX

## Rider Reach Explosion Proof Truck

### Specifications for 4,000 lb. Capacity



**Standard Mast Specifications (inches)**

- ★ All Gregory Explosion Proof (EX) rated forklifts can be custom designed in accordance with the individual specifications of each customer.
- ★ Specifications on this sheet provide standard dimensions for the 4,000 lb. capacity RR model. Capacities from 3,000 lb. to 6,000 lb. are available.
- ★ Contact the American Specialty Equipment Sales Department for custom requirements or other mast specifications.

Mast Type	(A) Collapsed Height	(B) Maximum Fork Height	(C) Free Lift	(D) Overall Extended Height
Standard	71	103.5	5.5	136.5
	83	127.5	5.5	160.5
Duplex	77	115.5	43	148.5
	83	127.5	49	160.5
Triplex	77	170	43	203
	83	188	49	221
	87	198	53	231
	89	202	55	235

Classified to U.S. and Canadian Safety Standards by Underwriters Laboratories Inc. for Use in Class I, Divisions 1 & 2, Group D; Class II, Divisions 1 & 2, Group G; and Class III, Divisions 1 & 2 Hazardous Environments. CE Marked to Conform with European Standards.



## Rider Reach Explosion Proof Truck

<b>General Information</b>	<b>Manufacturer</b>	American Specialty Equipment, Inc.
	<b>Model</b>	Gregory RR4EX
	<b>Capacity</b>	RR4EX - 4,000 lb. at 24" Load Center
	<b>Rating</b>	UL Classified Explosion Proof
	<b>Power</b>	24 Volt Electric
	<b>Electric Controls</b>	Transistorized, Solid State Infinitely Variable Programmable Speed, Acceleration and Plugging Capabilities
	<b>Hydraulic Controls</b>	Point of Action Electric / Hydraulic Infinitely Variable
	<b>Motors (Drive, Lift, Power Steering)</b>	Heavy Duty Explosion Proof with Class "H" Insulation, UL Classified
	<b>Power Steering</b>	Hydrostatic
	<b>Forks (Bronze Covered)</b>	Shaft Mount 1.75 x 4.25 x 42 Other Sizes Available
	<b>Truck Weight (Less Battery)</b>	5,200 lb.
	<b>Paint</b>	Safety Yellow
<b>Dimensions</b>	<b>Specifications and Mast Options Shown on Front</b>	
<b>Performance</b>	<b>Maximum Travel Speeds</b>	4.8 mph Empty, 4.0 mph Loaded Programmable
	<b>Lift / Lower Speeds</b>	<b>Standard:</b> 55 / 75 fpm Empty 45 / 75 fpm Loaded <b>Duplex Hi-Free Lift:</b> 45 / 75 fpm Empty 40 / 75 fpm Loaded <b>Triplex:</b> 55 / 75 fpm Empty 40 / 75 fpm Loaded
	<b>Equal Intersecting Aisle</b>	77"
	<b>Right Angle Stacking</b>	110"
	<b>Gradeability</b>	10%
<b>Chassis</b>	<b>Wheels, Drive</b>	(2) 12" x 3.5" Static Conductive Rubber
	<b>Wheels, Load</b>	(4) 5" x 3.63" Polyurethane
	<b>Brake</b>	Deadman Foot Pedal
	<b>Underclearance</b>	2" Standard Higher Ramp Underclearances Available
<b>Battery and Charger Requirements</b>	<b>Battery Type</b>	UL Classified Explosion Proof
	<b>Battery Capacity</b>	500 Amp Standard - 620 Amp Available
	<b>Battery Compartment</b>	11.25" x 25.6" x 34.5" Side Removal
	<b>Battery Weight</b>	985 lbs.
	<b>Charger Connector</b>	N2106 Explosion Proof

### \* UL Approved Group C Label Option:

An optional feature of the Gregory Rider Reach Explosion Proof Truck is a UL Approved Group C Label. Gregory Explosion Proof Group C Labeled Trucks are Classified to U.S. Safety Standards by Underwriters Laboratories for use in Class I, Divisions 1 & 2, Group C Environments.

American Specialty Equipment, Inc. produces a complete line of specialized Material Handling Equipment. Continuous improvements in safety, performance and durability assure customers of a quality forklift designed to meet their specifications.

All vehicles are furnished with UL mandated safety devices and under no circumstances should these devices be removed. Gregory products and specifications are subject to improvements and changes without notice and obligation on prior purchases.

### Standard Features

24 Volt System  
Battery Discharge Indicator w/ Lift Interrupt  
Battery Roller Tray  
Bronze Anti-Spark Package  
Electric Horn and Back-Up Alarm Package  
Emergency Power Disconnect  
Fire Extinguisher  
Hourmeter  
Hydrostatic Power Steering  
Internal Mast Reeving  
Overhead Guard  
Sight Glass  
Static Conductive Drive Tires  
Transistorized Controls

### Optional Features

Epoxy Paint  
Hand Held Analyzer  
Hydraulic Attachments  
On/Off Key Switch  
Remote In-Environment Charging Station  
Stainless Steel Construction  
Strobe Light  
UL Approved Group C Label \*

**Gregory EX Trucks** are Classified to U.S. and Canadian Safety Standards by Underwriters Laboratories Inc. for use in **Class I, Divisions 1 & 2, Group D;** **Class II, Divisions 1 & 2, Group G;** and **Class III, Divisions 1 & 2** Environments.

All Gregory EX trucks are classified by UL to the following Standards for Safety:

#### UL 583

Electric-Battery-Powered Industrial Trucks

#### UL 1203

Explosion Proof and Dust-Ignition-Proof Electrical Equipment for Use in Hazardous (Classified) Locations

#### UL 1604

Electrical Equipment for Use in Class I and Class II, Division 2, and Class III Hazardous (Classified) Locations

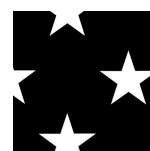

**AMERICAN  
SPECIALTY  
EQUIPMENT**

Manufacturer of Gregory Industrial Trucks  
15 Daniel Road Fairfield, NJ 07004-2506  
phone: (973) 882-3190 fax: (973) 808-8398  
web site: [www.exforklifts.com](http://www.exforklifts.com)  
e-mail: [sales@exforklifts.com](mailto:sales@exforklifts.com)