

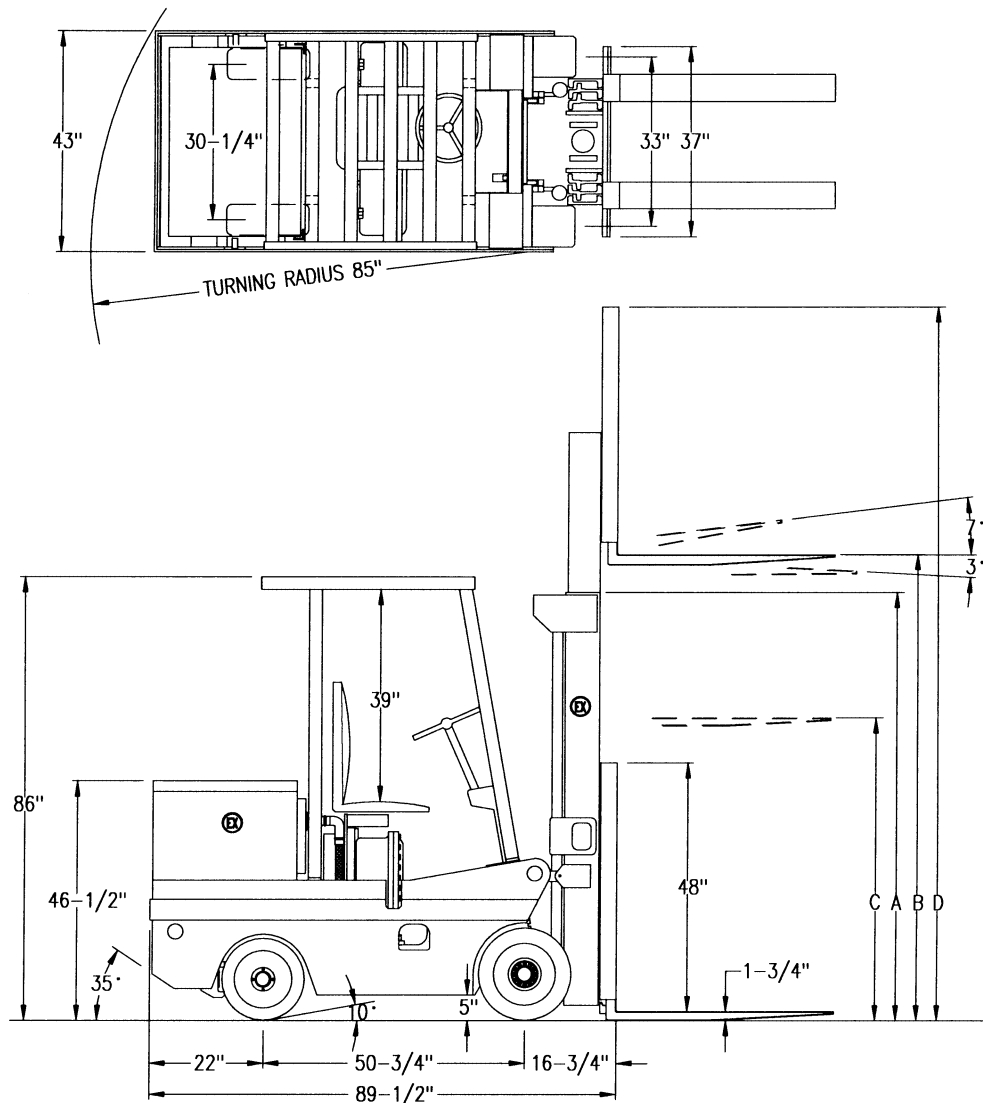

# GREGORY Model RSC-EX

## Rider Sitdown Counterbalanced Explosion Proof Truck Specifications for 3,000 lb. and 4,000 lb. Capacities



**Standard Mast Specifications (inches)**

Mast Type	(A) Collapsed Height	(B) Maximum Fork Height	(C) Free Lift	(D) Overall Extended Height
Duplex	77	115.5	52.9	163.5
	83	127.5	58.9	175.5
Triplex	71	152	46.9	200
	77	170	52.9	218
	83	188	58.9	236
	87	198	62.9	246
	89	202	64.9	250
	95	216	70.9	264

★ All Gregory Explosion Proof (EX) rated forklifts can be custom designed in accordance with the individual specifications of each customer.

★ Specifications on this sheet provide standard dimensions for 3,000 lb. and 4,000 lb. capacity RSC models. Capacities to 8,000 lb. are available.

★ Contact the American Specialty Equipment Sales Department for custom requirements or other mast specifications.

Classified to U.S. and Canadian Safety Standards by Underwriters Laboratories Inc. for Use in Class I, Divisions 1 & 2, Group D; Class II, Divisions 1 & 2, Group G; and Class III, Divisions 1 & 2 Hazardous Environments. CE Marked to Conform with European Standards.



<b>Rider Sitdown Counterbalanced Explosion Proof Truck</b>		
<b>General Information</b>	<b>Manufacturer</b>	American Specialty Equipment, Inc.
	<b>Model</b>	Gregory RSC3EX and RSC4EX
	<b>Capacity</b>	RSC3EX - 3,000 lb. at 24" Load Center RSC4EX - 4,000 lb. at 24" Load Center
	<b>Rating</b>	UL Classified Explosion Proof
	<b>Power</b>	36 Volt Electric
	<b>Electric Controls</b>	Infinitely Variable
	<b>Hydraulic Controls</b>	Point of Action Electric / Hydraulic Infinitely Variable
	<b>Motors (Drive, Lift, Power Steering)</b>	Heavy Duty Explosion Proof with Class "H" Insulation, UL Classified
	<b>Power Steering</b>	Hydrostatic
	<b>Wheels</b>	4 Cushioned Tires
	<b>Forks (Bronze Covered)</b>	Class II, 1.75 x 4.25 x 36, 40, 42, 48, 60 Other Sizes Available
	<b>Truck Weight (Less Battery)</b>	6,550 lbs.
	<b>Paint</b>	Safety Yellow
<b>Dimensions</b>	<b>Specifications and Mast Options Shown on Front</b>	
<b>Performance</b>	<b>Maximum Travel Speeds</b>	4.5 mph Empty, 4.0 mph Loaded
	<b>Lift / Lower Speeds</b>	<b>Duplex Standard:</b> 65 / 60 fpm Empty 45 / 65 fpm Loaded <b>Duplex Hi-Free Lift:</b> 55 / 40 fpm Empty 40 / 60 fpm Loaded <b>Triplex:</b> 55 / 60 fpm Empty 40 / 90 fpm Loaded
	<b>Equal Intersecting Aisle</b>	80"
	<b>Right Angle Stacking</b>	102" + Load
	<b>Gradeability</b>	15%
	<b>Chassis</b>	<b>Drive Tires</b>
<b>Steer Tires</b>		16-1/4" x 6" x 11-1/4" Rubber Static
<b>Wheelbase</b>		50-3/4" High Stability
<b>Brakes</b>		<b>Safety:</b> Seat Actuated <b>Service:</b> Internal Expanding 4 Wheel Split System <b>Parking:</b> Lever Actuated
<b>Battery and Charger Requirements</b>	<b>Battery Type</b>	UL Classified Explosion Proof 18 Cell, 19 Plate
	<b>Battery Capacity</b>	765 Amp Standard - 900 Amp Available
	<b>Battery Compartment</b>	26.5" x 37.375" x 24.5" Overhead Removal
	<b>Battery Weight</b>	2,500 lbs. Minimum
	<b>Charger Connector</b>	N2106 Explosion Proof

American Specialty Equipment, Inc. produces a complete line of specialized Material Handling Equipment. Continuous improvements in safety, performance and durability assure customers of a quality forklift designed to meet their specifications.

All vehicles are furnished with UL mandated safety devices and under no circumstances should these devices be removed. Gregory products and specifications are subject to improvements and changes without notice and obligation on prior purchases.

<b>Standard Features</b>
4 Wheel Dual System Brakes
48" Load Backrest
Antifatigue Seating
Battery Discharge Indicator w/ Lift Interrupt
Bronze Clad Forks
Driver Restraint System
Electric Back-Up Alarm
Electric Horn
Emergency Power Disconnect
Fire Extinguisher
Hourmeter
Hydrostatic Power Steering
Independent Hand Brake
Internal Mast Reeving
Non Sparking Bumper
Overhead Guard
RFI Suppression MIL-STD/461/Class III C
Seat Actuated Parking Brake
Sight Glass
Static Conducting Tires
Transistorized Controls
<b>Optional Features</b>
Hydraulic Attachments
Remote In-Environment Charging Station
Sideshifter
Strobe Light

**Gregory EX Trucks** are Classified to U.S. and Canadian safety standards by Underwriters Laboratories Inc. for use in **Class I, Divisions 1 & 2, Group D;** **Class II, Divisions 1 & 2, Group G;** and **Class III, Divisions 1 & 2** Environments.

All Gregory EX trucks are classified by UL to the following Standards for Safety:

**UL 583**

Electric-Battery-Powered Industrial Trucks

**UL 1203**

Explosion Proof and Dust-Ignition-Proof Electrical Equipment for Use in Hazardous (Classified) Locations

**UL 1604**

Electrical Equipment for Use in Class I and Class II, Division 2, and Class III Hazardous (Classified) Locations

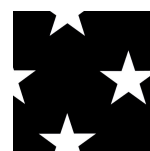

**AMERICAN  
SPECIALTY  
EQUIPMENT**

Manufacturer of Gregory Industrial Trucks  
15 Daniel Road Fairfield, NJ 07004-2506  
phone: (973) 882-3190 fax: (973) 808-8398  
web site: [www.exforklifts.com](http://www.exforklifts.com)  
e-mail: [sales@exforklifts.com](mailto:sales@exforklifts.com)